

3-составные шаровые краны серии S7500/S7700

Технические характеристики



Архангельск (8182)63-90-72
Астана (7172)727-132
Астрахань (8512)99-46-04
Барнаул (3852)73-04-60
Белгород (4722)40-23-64
Брянск (4832)59-03-52
Владивосток (423)249-28-31
Волгоград (844)278-03-48
Вологда (8172)26-41-59
Воронеж (473)204-51-73
Екатеринбург (343)384-55-89
Иваново (4932)77-34-06

Ижевск (3412)26-03-58
Иркутск (395)279-98-46
Казань (843)206-01-48
Калининград (4012)72-03-81
Калуга (4842)92-23-67
Кемерово (3842)65-04-62
Киров (8332)68-02-04
Краснодар (861)203-40-90
Красноярск (391)204-63-61
Курск (4712)77-13-04
Липецк (4742)52-20-81
Киргизия (996)312-96-26-47

Магнитогорск (3519)55-03-13
Москва (495)268-04-70
Мурманск (8152)59-64-93
Набережные Челны (8552)20-53-41
Нижний Новгород (831)429-08-12
Новокузнецк (3843)20-46-81
Новосибирск (383)227-86-73
Омск (3812)21-46-40
Орел (4862)44-53-42
Оренбург (3532)37-68-04
Пенза (8412)22-31-16
Казахстан (772)734-952-31

Пермь (342)205-81-47
Ростов-на-Дону (863)308-18-15
Рязань (4912)46-61-64
Самара (846)206-03-16
Санкт-Петербург (812)309-46-40
Саратов (845)249-38-78
Севастополь (8692)22-31-93
Симферополь (3652)67-13-56
Смоленск (4812)29-41-54
Сочи (862)225-72-31
Ставрополь (8652)20-65-13
Таджикистан (992)427-82-92-69

Сургут (3462)77-98-35
Тверь (4822)63-31-35
Томск (3822)98-41-53
Тула (4872)74-02-29
Тюмень (3452)66-21-18
Ульяновск (8422)24-23-59
Уфа (347)229-48-12
Хабаровск (4212)92-98-04
Челябинск (351)202-03-61
Череповец (8202)49-02-64
Ярославль (4852)69-52-93

Единый адрес для всех регионов: bya@nt-rt.ru | | www.bray.nt-rt.ru

3-составные шаровые краны серии S7500/S7700

HIGH PURITY APPLICATIONS

Flow-Tek's Micro Pure Series ball valves have been specifically designed to meet the requirements of high purity applications in accordance with ASME BPEa specification. All valve bodies are investment cast CF3M (316L) stainless steel with an internal surface finish of 15 Ra with 20 Ra maximum per SFV-1. Other grades of surface finishes, including electropolishing are available. Cavity fillers and purge ports are also available upon request.

Tube Bore The ball and end connections of all Micro Pure Series valves have the same I.D. dimension as the mating tube system. These valves offer smooth flow characteristics with minimal pressure drop and full drain capability.

Processing To prevent component contamination, Micro Pure Series valves are solution cleaned, assembled and bagged to allow for use in high purity systems.



Size	Steam Rating	Temperature Range	Pressure Rating	End Connections	Body Material
1/2" to 4" 8mm to 100mm	150 psi WSP 10.3 bar	-50°F to +450°F -46°C to +232°C	1000 psi WOG 69 bar <i>(Dependent on end connection selected.)</i>	Quick Clamp Extended Tube End SAE Male <i>(End connections are interchangeable within the Micro Pure Series)</i>	Stainless Steel

FEATURES AND BENEFITS



BALL

Flow-Tek balls are precision machined and mirror finished for bubble-tight shut off and reduced operating torque.

SEAT

Flow-Tek's unique seat design ensures bidirectional sealing while providing the lowest possible torque.

SEAT SELECTION

Optional seat materials, such as TFM 1600, are available to meet most applications, with the standard seat being Virgin PTFE. Optional seat designs, such as Cavity Fillers, are also available upon request.

BODY

1/2" - 4" valve bodies are investment cast stainless steel and all bodies are solution annealed for the highest quality and added strength. All body castings are marked with a foundry heat number for full traceability. The three piece body design offers many advantages, including installation flexibility, elimination of the need of flanges, and ease of in line or out of line servicing.

BODY HINGES

Two heavy duty body bolt hinges, throughout the entire size range, provide positive alignment of body to end connection during in-line servicing.

END CONNECTIONS

The Micro Pure Series features two standard interchangeable end connections; Quick Clamps for ease of installation and Extended Tube Ends for weld-in-place service.

SECURE MOUNT

A unique standard feature is an integrally cast top flange that ensures positive actuator mounting. Flow-Tek's Secure Mount eliminates unwanted actuator movement during high cycle or continuous duty applications. Actuation equipment can be easily and safely removed while the valve is under full line pressure. The Secure Mount through 2" valve sizes is in compliance with ISO 5211 bolting pattern standards.

HANDLES

1/2" - 2" manually operated valves feature as standard a Safety Trigger to prevent accidental movement of the valve handle. The trigger locks the handle in the open or closed position. The handle lock can be overridden, if needed, with a small bolt through the handle in the release position. An oval handle is also available as an option.

PADLOCK

A padlock can be added to secure the handle in position, preventing unwanted access. Available as standard on all valve sizes.

SMART STEM ASSEMBLIES

Flow-Tek manufactures heavy duty, high quality stems. All Flow-Tek stems are internal entry and blowout proof for maximum safety. Micro Pure Series valves feature strong, large diameter stems with live-loaded, self-adjusting primary and secondary sealing. Utilizing Belleville washers, the stem seal automatically adjusts to compensate for changes in temperature and normal wear. The assembly is secured by a saddle-type lock washer, preventing unthreading of stem nuts in high cycle automation applications.

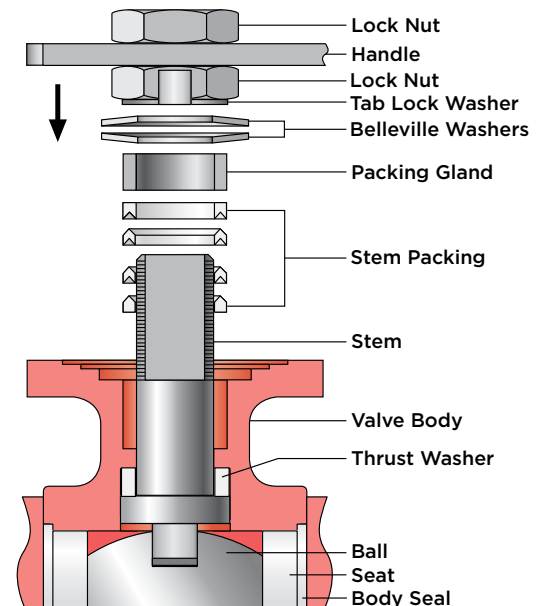

STEM SEALS

The Thrust Washer provides the primary seal while the live loaded Stem Packing creates a multiple secondary seal between the stem and body. The stem packing is also composed of PTFE providing high purity protection and high cycle life. This dual stem seal arrangement is a Flow-Tek exclusive.

DOUBLE LOCK NUT DESIGN

Standard on the Micro Pure Series, the double lock nuts with tab lock washer allow handles to be easily and safely removed while the valve is under full line pressure.

SPECIFICATIONS

Valve Sizes 1/2" through 4"

Valve designs are in accordance with ASME BPEa High Purity Valves.

Valve bodies and end connections are high quality investment cast and solution annealed. Body shell wall thickness complies with ASME B16.34.

BPEa compliant with <3% ferrite and .005 to .017 sulfur content in the extended tube ends for orbital welding.

Valve stems are blow-out proof for maximum safety and comply with ASME B16.34.

All standard materials of construction comply with FDA requirements and all soft goods meet USP Class VI standards.

PRESSURE RATINGS

Valve Body1000 psi WOG
Steam Rating 150 psi WSP
Vacuum29 inches Hg

PRESSURE/TEMPERATURE

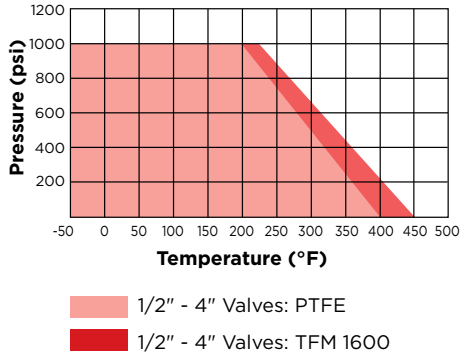

INTERNAL SURFACE FINISHES

BPE Designation	Ra Average	Ra Max
SFV1*	Mechanical Polished 15	20
SFV4	Mechanical and Electropolished 10	15

*Flow-Tek standard

Flow-Tek offers the seat/body seal, thrust washers, and soft material stem packing as recommended spare parts. These parts are available as a packaged repair kit.

COMPONENTS & MATERIALS

For Valve Sizes 1/2" through 2"

For 2 1/2" - 4" consult factory

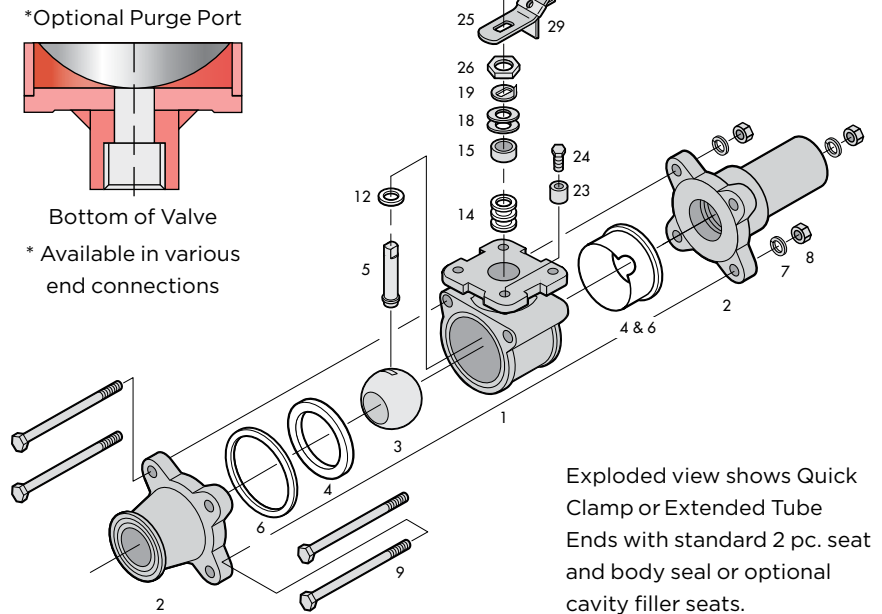

Exploded view shows Quick Clamp or Extended Tube Ends with standard 2 pc. seat and body seal or optional cavity filler seats.

Item	Name	Material	Qty.
1	Body	ASTM A351 Gr CF3M [†]	1
2	End Cap	ASTM A351 Gr CF3M [†]	2
3	Ball	ASTM A351 Gr CF3M [†]	1
4 & 6	Seat/Cavity Filler & Body Seal*	PTFE	2
5	Stem	ASTM A479 Type316	1
7	Spring Washer	SS304	4**
8	Body Nut	SS304	4**
9	Body Bolt	SS304	4**
12	Thrust Washer	PTFE	1
14	Stem Packing	PTFE	3
15	Packing Gland	SS304	1
18	Belleville Washer	SS301	2
19	Tab Lock Washer	SS304	1
23	Travel Stop Set Sleeve	SS304	1
24	Travel Stop Bolt	SS304	1
25	Handle	SS304	1
26	Lock Nut	SS304	2
28	Handle Sleeve	Vinyl	1
29	Locking Device	SS304	1

[†]Sizes 2 1/2, 3 and 4" are ASTM A351 Gr CF8M.

*Standard valve has a seat and body seal. Cavity Filler and Body Seal are optional.

**Quantity is 6 for 3" and 4" valves.

DIMENSIONS

Size in / mm	A1	A2	øB Port	øB1	C	C1	D	E	C _v	Wgt. lb / kg	Bolt Torque lb-in / Nm	Break Torque lb-in / Nm	
												Without Cavity Filler	With Cavity Filler
1/2	3.602	6.00	0.370	0.370	2.60	1.535	6.496	1.50	9.5	2	150	42	55
15	91.5	152.4	9.4	9.4	66	39	165	38.1		0.9	17	4.8	6.2
3/4	4.114	6.00	0.620	0.620	2.60	1.535	6.496	1.50	30	3	150	70	90
20	104.5	152.4	15.8	15.8	66	39	165	38.1		1.4	17	7.9	10.2
1	4.480	6.50	0.870	0.870	2.91	1.658	6.496	1.50	65	4	150	115	150
25	113.8	165.1	22.1	22.1	73.9	42	165	38.1		1.8	17	13	17
1 1/2	5.055	7.50	1.370	1.370	3.62	2.254	7.874	1.50	205	7	280	285	370
40	128.4	190.5	34.3	34.3	91.9	57.3	200	38.1		3.2	32	33	42
2	5.748	8.50	1.870	1.870	4.53	2.953	9.842	1.50	420	10	285	465	605
50	146	215.9	47.5	47.5	115.1	75	250	38.1		4.5	32.2	53	69
2 1/2	6.850	10.0	2.370	2.370	5.04	3.386	9.646	1.50	430	20	330	650	845
65	174	254	60.2	60.2	128	86	245	38.1		9.1	37	74	96
3	7.402	11.5	2.870	2.870	6.42	3.720	15.354	1.75	675	32	600	950	1235
80	188	292.1	72.9	72.9	163.1	94.5	390	44.4		14.5	68	108	140
4	8.758	12.5	3.834	3.834	7.09	4.350	15.354	2.00	1110	55	650	3000	3900
100	222.5	317.5	97.4	97.4	180.1	110.5	390	50.8		24.9	73	339	441

Note: Torque at maximum rated pressure, clean water, PTFE seats. Refer to Technical Bulletin 1005 for complete torque information. Bolt torques are provided for proper reassembly of valve bodies after disassembly for installation or cleaning.

SECURE MOUNT

Size in / mm	H	J	K	L	M	øP	U UNC
1/2	1.169	1.169	0.35	0.61	0.250	0.375	10 - 24
15	29.7	29.7	8.9	15.5	6.35	9.5	
3/4	1.169	1.169	0.35	0.61	0.250	0.375	#10 - 24
20	29.7	29.7	8.9	15.5	6.35	9.5	
1	1.169	1.169	0.40	0.61	0.250	0.375	#10 - 24
25	29.7	29.7	10.2	15.5	6.35	9.5	
1 1/2	1.392	1.392	0.51	0.80	0.315	0.438	1/4" - 20
40	35.4	35.4	13	20.3	8	11.1	
2	1.949	1.949	0.62	0.94	0.374	0.625	5/16" - 18
50	49.5	49.5	15.8	23.9	9.5	15.9	
2 1/2	2.840	2.840	0.82	1.22	0.472	0.750	5/16" - 18
65	72.1	72.1	20.8	31	12	19.1	
3	3.543	1.874	1.752	3.00	0.669	1.102	1/2" - 13
80	90	47.6	44.5	76.2	17	28	
4	3.543	1.874	1.752	3.00	0.669	1.102	1/2" - 13
100	90	47.6	44.5	76.2	17	28	

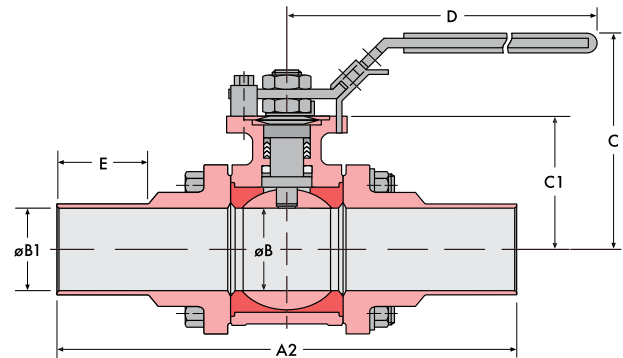

Extended Tube End Connections
Model S7700
SAE Male End Connections also Available

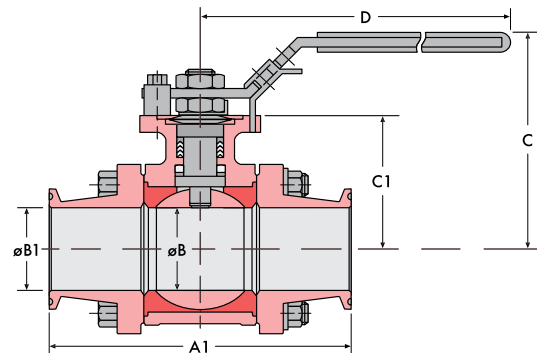

Quick Clamp End Connections
Model S7500

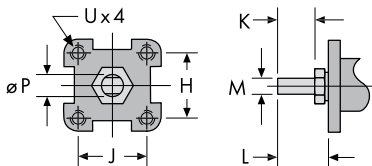

1/2" - 2" Valves

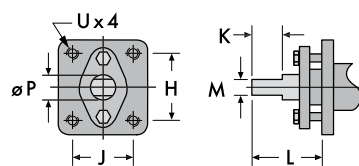

2 1/2" - 4" Valves

Архангельск (8182)63-90-72
Астана (7172)727-132
Астрахань (8512)99-46-04
Барнаул (3852)73-04-60
Белгород (4722)40-23-64
Брянск (4832)59-03-52
Владивосток (423)249-28-31
Волгоград (844)278-03-48
Вологда (8172)26-41-59
Воронеж (473)204-51-73
Екатеринбург (343)384-55-89
Иваново (4932)77-34-06
Ижевск (3412)26-03-58
Иркутск (395)279-98-46
Казань (843)206-01-48
Калининград (4012)72-03-81
Калуга (4842)92-23-67
Кемерово (3842)65-04-62
Киров (8332)68-02-04
Краснодар (861)203-40-90
Красноярск (391)204-63-61
Курск (4712)77-13-04
Липецк (4742)52-20-81
Киргизия (996)312-96-26-47
Магнитогорск (3519)55-03-13
Москва (495)268-04-70
Мурманск (8152)59-64-93
Набережные Челны (8552)20-53-41
Нижний Новгород (831)429-08-12
Новокузнецк (3843)20-46-81
Новосибирск (383)227-86-73
Омск (3812)21-46-40
Орел (4862)44-53-42
Оренбург (3532)37-68-04
Пенза (8412)22-31-16
Казахстан (772)734-952-31
Пермь (342)205-81-47
Ростов-на-Дону (863)308-18-15
Рязань (4912)46-61-64
Самара (846)206-03-16
Санкт-Петербург (812)309-46-40
Саратов (845)249-38-78
Севастополь (8692)22-31-93
Симферополь (3652)67-13-56
Смоленск (4812)29-41-54
Сочи (862)225-72-31
Ставрополь (8652)20-65-13
Таджикистан (992)427-82-92-69
Сургут (3462)77-98-35
Тверь (4822)63-31-35
Томск (3822)98-41-53
Тула (4872)74-02-29
Тюмень (3452)66-21-18
Ульяновск (8422)24-23-59
Уфа (347)229-48-12
Хабаровск (4212)92-98-04
Челябинск (351)202-03-61
Череповец (8202)49-02-64
Ярославль (4852)69-52-93

Единый адрес для всех регионов: bya@nt-rt.ru | | www.bray.nt-rt.ru