

Краны шаровые резьбовые серии S70/S90

Технические характеристики



Архангельск (8182)63-90-72
Астана (7172)727-132
Астрахань (8512)99-46-04
Барнаул (3852)73-04-60
Белгород (4722)40-23-64
Брянск (4832)59-03-52
Владивосток (423)249-28-31
Волгоград (844)278-03-48
Вологда (8172)26-41-59
Воронеж (473)204-51-73
Екатеринбург (343)384-55-89
Иваново (4932)77-34-06

Ижевск (3412)26-03-58
Иркутск (395)279-98-46
Казань (843)206-01-48
Калининград (4012)72-03-81
Калуга (4842)92-23-67
Кемерово (3842)65-04-62
Киров (8332)68-02-04
Краснодар (861)203-40-90
Красноярск (391)204-63-61
Курск (4712)77-13-04
Липецк (4742)52-20-81
Киргизия (996)312-96-26-47

Магнитогорск (3519)55-03-13
Москва (495)268-04-70
Мурманск (8152)59-64-93
Набережные Челны (8552)20-53-41
Нижний Новгород (831)429-08-12
Новокузнецк (3843)20-46-81
Новосибирск (383)227-86-73
Омск (3812)21-46-40
Орел (4862)44-53-42
Оренбург (3532)37-68-04
Пенза (8412)22-31-16
Казахстан (772)734-952-31

Пермь (342)205-81-47
Ростов-на-Дону (863)308-18-15
Рязань (4912)46-61-64
Самара (846)206-03-16
Санкт-Петербург (812)309-46-40
Саратов (845)249-38-78
Севастополь (8692)22-31-93
Симферополь (3652)67-13-56
Смоленск (4812)29-41-54
Сочи (862)225-72-31
Ставрополь (8652)20-65-13
Таджикистан (992)427-82-92-69

Сургут (3462)77-98-35
Тверь (4822)63-31-35
Томск (3822)98-41-53
Тула (4872)74-02-29
Тюмень (3452)66-21-18
Ульяновск (8422)24-23-59
Уфа (347)229-48-12
Хабаровск (4212)92-98-04
Челябинск (351)202-03-61
Череповец (8202)49-02-64
Ярославль (4852)69-52-93

Единый адрес для всех регионов: bya@nt-rt.ru | www.bray.nt-rt.ru

Краны шаровые резьбовые серии S70/S90

Flow-Tek's Series S70 and Series S90 ball valves offer an economical solution for high pressure applications in the process industries. Standard 2-piece valve bodies are available in stainless steel or carbon steel. Stainless steel bodies are investment cast and solution annealed for the highest quality and added strength. Cast carbon steel bodies are normalized and black phosphate coated for added corrosion resistance. All body castings are marked with a foundry heat number for full traceability. These quarter turn valves feature an adjustable packing gland for secure sealing.

Other features include low operating torque, internal bottom entry blowout proof stems, and stainless steel safety latch handles.



Size	Pressure Rating	Steam Rating	Temperature Range	End Connections	Body Material
1/4" to 1" 8mm to 25mm	2000 psi WOG 41.4 bar	150 psi WSP 10.3 bar	S70 -50°F to +450°F -46°C to +232°C	Threaded - NPT	S70 316 Stainless Steel
1-1/4" to 2" 32mm to 50mm	1500 psi WOG 27.6 bar		S90 -20°F to +450°F -29°C to +232°C		S90 WCB Carbon Steel
2-1/2" to 3" 65mm to 80mm	1000 psi WOG ???				

DIMENSIONS AND WEIGHTS

Size ins mm	A	øB Port	C	C1	D	E	K	L	M	øP	V	U UNC	Cv	Torque		Weight	
														lbs-in*	Nm	lbs	kg
1/4	2.17	0.44	2.17	0.93	4.0	1.65	0.39	0.59	0.25	0.37	1.65	#10-24	15	60	0.55		
6	55.1	11.2	55.1	23.6	102	42	10	15	6.4	9.4	42			6.8	0.25		
3/8	2.17	0.49	2.17	0.93	4.0	1.65	0.39	0.59	0.25	0.37	1.65	#10-24	15	60	0.55		
10	55.1	12.4	55.1	23.6	102	42	10	15	6.4	9.4	42			6.8	0.25		
1/2	2.56	0.59	2.17	0.93	4.0	1.65	0.39	0.59	0.25	0.37	1.65	#10-24	15	65	0.65		
15	65	15	55.1	23.6	102	42	10	15	6.4	9.4	42			7.3	0.3		
3/4	2.80	0.59	2.36	1.1	4.0	1.65	0.39	0.59	0.25	0.37	1.65	#10-24	40	65	1.10		
20	71.1	15	59.9	28	102	42	10	15	6.4	9.4	42			7.3	0.5		
1	3.23	0.79	2.68	1.38	5.0	1.65	0.47	0.71	0.26	0.44	1.65	#10-24	70	130	2.00		
25	82	20.1	68.1	35	127	42	12	18	6.5	11.2	42			14.7	0.9		
1-1/4	3.62	0.98	2.87	1.54	5.0	1.65	0.47	0.77	0.26	0.44	1.65	#10-24	120	210	3.00		
32.5	91.9	24.9	72.9	39	127	42	12	19.6	6.5	11.2	42			23.7	1.4		
1-1/2	4.06	1.26	3.35	1.87	6.5	1.97	0.57	0.94	0.37	0.62	1.97	1/4"-20	200	260	4.25		
40	103.1	32	85.1	47.5	165	50	14.5	23.9	9.5	15.7	50			29.4	1.9		
2	4.65	1.50	3.64	2.17	7.5	2.56	0.57	0.94	0.37	0.62	2.76	5/16"-18	340	315	6.75		
50	118.1	38.1	92.5	55	190	65	14.5	23.9	9.5	15.7	70			35.6	3.1		
2-1/2	5.39	2.00	3.94	2.46	7.5	2.56	0.57	0.94	0.37	0.62	2.76	5/16"-18	400	425	9.50		
65	136.9	50.8	101.1	62.5	190	65	14.5	23.9	9.5	15.7	70			48	4.3		
3	6.20	2.56	4.65	3.07	10.25	2.56	0.85	1.28	0.47	0.75	2.76	5/16"-18	675	530	16.5		
80	157.5	65	118.1	78	260	65	21.6	32.5	12	19	70			59.9	7.5		

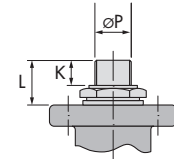
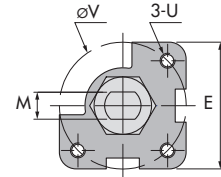
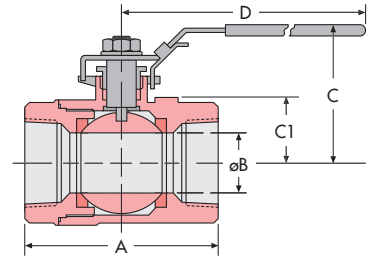

COMPONENTS AND MATERIALS

Item	Name	S70 Stainless Steel	S90 Carbon Steel	Qty.
1	Body	ASTM A351 Gr CF8M	ASTM A216 Gr WCB	1
2	End Cap	ASTM A351 Gr CF8M	ASTM A216 Gr WCB	1
3	Ball	ASTM A351 Gr CF8M	ASTM A351 Gr CF8M	1
4	Seat	RTFE	RTFE	2
5	Stem	ASTM A479 Type 316	ASTM A351 Type 316	1
6	Body Seal	RTFE	RTFE	1
7	Spring Washer	SS304	SS304	1
10	Anti-Static Device	SS304	SS304	2
12	Thrust Washer	RTFE	RTFE	1
14	Stem Packing	RTFE	RTFE	2
15	Packing Gland	SS304	SS304	1
25	Handle	SS304	SS304	1
26	Nut	SS304	SS304	1
28	Handle Sleeve	Vinyl	Vinyl	1
29	Locking Device	SS304	SS304	1

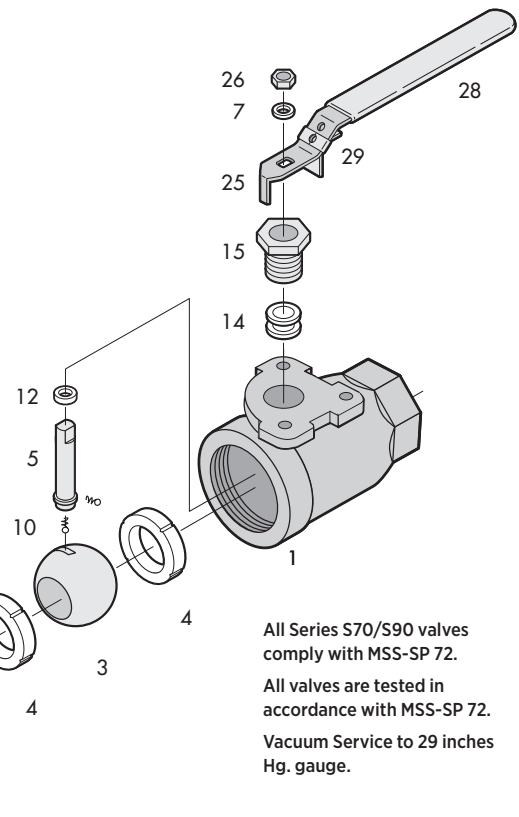

All Series S70/S90 valves comply with MSS-SP 72.

All valves are tested in accordance with MSS-SP 72.

Vacuum Service to 29 inches Hg. gauge.

PRESSURE/TEMPERATURE

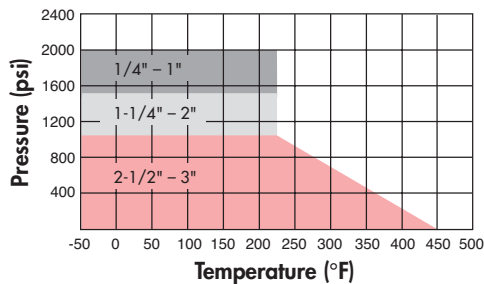

NOTE: S90 Carbon steel temperature range limited to -20°F to +450°F.

STEAM RATING: 150 psi WSP.

Архангельск (8182)63-90-72
Астана (7172)727-132
Астрахань (8512)99-46-04
Барнаул (3852)73-04-60
Белгород (4722)40-23-64
Брянск (4832)59-03-52
Владивосток (423)249-28-31
Волгоград (844)278-03-48
Вологда (8172)26-41-59
Воронеж (473)204-51-73
Екатеринбург (343)384-55-89
Иваново (4932)77-34-06
Ижевск (3412)26-03-58
Иркутск (395)279-98-46
Казань (843)206-01-48
Калининград (4012)72-03-81
Калуга (4842)92-23-67
Кемерово (3842)65-04-62
Киров (8332)68-02-04
Краснодар (861)203-40-90
Красноярск (391)204-63-61
Курск (4712)77-13-04
Липецк (4742)52-20-81
Киргизия (996)312-96-26-47
Магнитогорск (3519)55-03-13
Москва (495)268-04-70
Мурманск (8152)59-64-93
Набережные Челны (8552)20-53-41
Нижний Новгород (831)429-08-12
Новокузнецк (3843)20-46-81
Новосибирск (383)227-86-73
Омск (3812)21-46-40
Орел (4862)44-53-42
Оренбург (3532)37-68-04
Пенза (8412)22-31-16
Казахстан (772)734-952-31
Пермь (342)205-81-47
Ростов-на-Дону (863)308-18-15
Рязань (4912)46-61-64
Самара (846)206-03-16
Санкт-Петербург (812)309-46-40
Саратов (845)249-38-78
Севастополь (8692)22-31-93
Симферополь (3652)67-13-56
Смоленск (4812)29-41-54
Сочи (862)225-72-31
Ставрополь (8652)20-65-13
Таджикистан (992)427-82-92-69
Сургут (3462)77-98-35
Тверь (4822)63-31-35
Томск (3822)98-41-53
Тула (4872)74-02-29
Тюмень (3452)66-21-18
Ульяновск (8422)24-23-59
Уфа (347)229-48-12
Хабаровск (4212)92-98-04
Челябинск (351)202-03-61
Череповец (8202)49-02-64
Ярославль (4852)69-52-93

Единый адрес для всех регионов: bya@nt-rt.ru | | www.bray.nt-rt.ru