

Краны шаровые резьбовые серии S51

Технические характеристики



Архангельск (8182)63-90-72
Астана (7172)727-132
Астрахань (8512)99-46-04
Барнаул (3852)73-04-60
Белгород (4722)40-23-64
Брянск (4832)59-03-52
Владивосток (423)249-28-31
Волгоград (844)278-03-48
Вологда (8172)26-41-59
Воронеж (473)204-51-73
Екатеринбург (343)384-55-89
Иваново (4932)77-34-06

Ижевск (3412)26-03-58
Иркутск (395)279-98-46
Казань (843)206-01-48
Калининград (4012)72-03-81
Калуга (4842)92-23-67
Кемерово (3842)65-04-62
Киров (8332)68-02-04
Краснодар (861)203-40-90
Красноярск (391)204-63-61
Курск (4712)77-13-04
Липецк (4742)52-20-81
Киргизия (996)312-96-26-47

Магнитогорск (3519)55-03-13
Москва (495)268-04-70
Мурманск (8152)59-64-93
Набережные Челны (8552)20-53-41
Нижний Новгород (831)429-08-12
Новокузнецк (3843)20-46-81
Новосибирск (383)227-86-73
Омск (3812)21-46-40
Орел (4862)44-53-42
Оренбург (3532)37-68-04
Пенза (8412)22-31-16
Казахстан (772)734-952-31

Пермь (342)205-81-47
Ростов-на-Дону (863)308-18-15
Рязань (4912)46-61-64
Самара (846)206-03-16
Санкт-Петербург (812)309-46-40
Саратов (845)249-38-78
Севастополь (8692)22-31-93
Симферополь (3652)67-13-56
Смоленск (4812)29-41-54
Сочи (862)225-72-31
Ставрополь (8652)20-65-13
Таджикистан (992)427-82-92-69

Сургут (3462)77-98-35
Тверь (4822)63-31-35
Томск (3822)98-41-53
Тула (4872)74-02-29
Тюмень (3452)66-21-18
Ульяновск (8422)24-23-59
Уфа (347)229-48-12
Хабаровск (4212)92-98-04
Челябинск (351)202-03-61
Череповец (8202)49-02-64
Ярославль (4852)69-52-93

Единый адрес для всех регионов: bya@nt-rt.ru | | www.bray.nt-rt.ru

Краны шаровые резьбовые серии S51

Flow-Tek's Series S51 brass ball valves are the ideal utility valve for low pressure commercial applications. The two-piece body construction offers simple quarter turn operation, low operating torque and bottom entry blowout proof stems. The balls are hard chromium plated brass for added durability and longevity. The Series S51's full port design minimizes pressure drops while maximizing flow.

The threaded end connections are manufactured with deeper grooves to ensure a positive connection. Easily adjustable stem packing seals prevent media leakage through the stem. Other features include vinyl insulated handles. This is an excellent valve for use in general service on water, steam, oil or compressed gases.

All Series S51 ball valves are CSA and UL listed and CE certified.



Size	Pressure Rating	Steam Rating	Temperature Range	End Connections	Body Material
1/4" to 2" 8mm to 50mm	600 psi WOG 41.4 bar	150 psi WSP 10.3 bar	-50°F to +400°F -46°C to +204°C	Threaded - NPT	Brass
2 1/2" to 4" 65mm to 100mm	400 psi WOG 27.6 bar	150 psi WSP 10.3 bar			

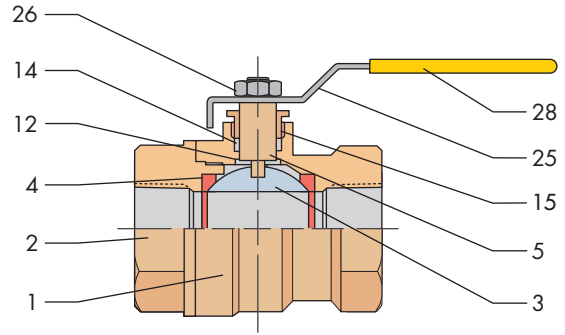
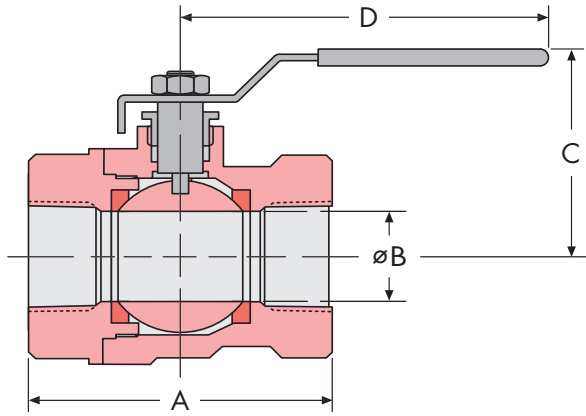

Components & Materials

Item	Name	Material	Qty.
1	Body	Brass	1
2	End Connection	Brass	1
3	Ball	Brass (Chrome Plated)	1
4	Seat	PTFE	1
5	Stem	Brass	1
12	Thrust Washer	RPTFE	1
14	Stem Packing	PTFE	1
15	Packing Nut	Brass	1
25	Handle	Zinc Plated Steel	1
26	Handle Nut	Zinc Plated Steel	1
28	Handle Sleeve	Vinyl	1

Dimensions

Size ins mm	A	ØB Port	C	D	C _v	Torque lbs-in.	Weight lbs kg
1/4 6	1.75 44	0.40 10	1.28 32	3.54 89	7.5	20	0.3 .14
3/8 10	1.75 44	0.40 10	1.28 32	3.54 89	7.5	25	0.3 .14
1/2 15	2.04 51	0.59 14.8	1.92 48.2	3.54 89	16	50	0.5 .23
3/4 20	2.36 59.2	0.75 18.8	2.09 52.4	3.78 95	43	70	0.7 .32
1 25	2.75 69	0.95 23.8	2.56 64.2	4.53 114	58	90	1.1 .51
1 ¼ 32	3.30 82.8	1.26 31.4	2.95 74	4.53 114	105	125	1.6 .74
1 ½ 40	3.66 91.9	1.57 39.4	3.35 84.1	5.51 138	160	180	2.4 1.1
2 50	4.18 105	1.97 49.4	3.68 92.4	5.51 138	325	290	3.4 1.6
2½ 65	5.38 135	2.52 63.2	4.76 119.5	8.66 217.4	475	420	7.6 3.5
3 80	6.04 151.6	2.95 74	5.08 127.5	8.66 217.4	780	710	9.4 4.3
4 100	7.39 185.5	3.90 97.9	5.87 147.3	9.61 241	1350	930	16.9 7.8

Specifications

- Threaded end connections meet ASME B1.20.1 NPT.
- ¼" - 2" valves rated to 600psi non-shock cold water, oil, gas (WOG)
- ¼" - 4" valves rated to 150psi saturated steam (WSP)
- 2½" - 4" valves rated to 400psi WOG
- All valves are CSA & UL listed and CE certified

Pressure/Temperature

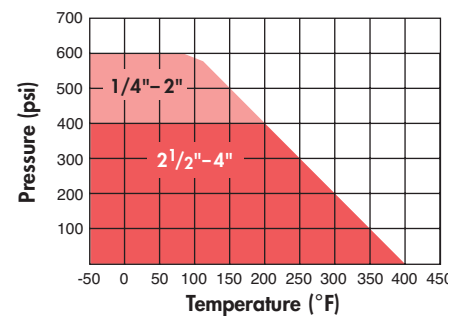

Testing

All valves are tested in accordance with MSS-SP72 at 100psi air under water in open and closed positions.

Архангельск (8182)63-90-72
Астана (7172)727-132
Астрахань (8512)99-46-04
Барнаул (3852)73-04-60
Белгород (4722)40-23-64
Брянск (4832)59-03-52
Владивосток (423)249-28-31
Волгоград (844)278-03-48
Вологда (8172)26-41-59
Воронеж (473)204-51-73
Екатеринбург (343)384-55-89
Иваново (4932)77-34-06
Ижевск (3412)26-03-58
Иркутск (395)279-98-46
Казань (843)206-01-48
Калининград (4012)72-03-81
Калуга (4842)92-23-67
Кемерово (3842)65-04-62
Киров (8332)68-02-04
Краснодар (861)203-40-90
Красноярск (391)204-63-61
Курск (4712)77-13-04
Липецк (4742)52-20-81
Киргизия (996)312-96-26-47
Магнитогорск (3519)55-03-13
Москва (495)268-04-70
Мурманск (8152)59-64-93
Набережные Челны (8552)20-53-41
Нижний Новгород (831)429-08-12
Новокузнецк (3843)20-46-81
Новосибирск (383)227-86-73
Омск (3812)21-46-40
Орел (4862)44-53-42
Оренбург (3532)37-68-04
Пенза (8412)22-31-16
Казахстан (772)734-952-31
Пермь (342)205-81-47
Ростов-на-Дону (863)308-18-15
Рязань (4912)46-61-64
Самара (846)206-03-16
Санкт-Петербург (812)309-46-40
Саратов (845)249-38-78
Севастополь (8692)22-31-93
Симферополь (3652)67-13-56
Смоленск (4812)29-41-54
Сочи (862)225-72-31
Ставрополь (8652)20-65-13
Таджикистан (992)427-82-92-69
Сургут (3462)77-98-35
Тверь (4822)63-31-35
Томск (3822)98-41-53
Тула (4872)74-02-29
Тюмень (3452)66-21-18
Ульяновск (8422)24-23-59
Уфа (347)229-48-12
Хабаровск (4212)92-98-04
Челябинск (351)202-03-61
Череповец (8202)49-02-64
Ярославль (4852)69-52-93

Единый адрес для всех регионов: bya@nt-rt.ru | | www.bray.nt-rt.ru