

# Краны шаровые резьбовые серии S20/FS20

## Технические характеристики



Архангельск (8182)63-90-72  
Астана (7172)727-132  
Астрахань (8512)99-46-04  
Барнаул (3852)73-04-60  
Белгород (4722)40-23-64  
Брянск (4832)59-03-52  
Владивосток (423)249-28-31  
Волгоград (844)278-03-48  
Вологда (8172)26-41-59  
Воронеж (473)204-51-73  
Екатеринбург (343)384-55-89  
Иваново (4932)77-34-06

Ижевск (3412)26-03-58  
Иркутск (395)279-98-46  
Казань (843)206-01-48  
Калининград (4012)72-03-81  
Калуга (4842)92-23-67  
Кемерово (3842)65-04-62  
Киров (8332)68-02-04  
Краснодар (861)203-40-90  
Красноярск (391)204-63-61  
Курск (4712)77-13-04  
Липецк (4742)52-20-81  
Киргизия (996)312-96-26-47

Магнитогорск (3519)55-03-13  
Москва (495)268-04-70  
Мурманск (8152)59-64-93  
Набережные Челны (8552)20-53-41  
Нижний Новгород (831)429-08-12  
Новокузнецк (3843)20-46-81  
Новосибирск (383)227-86-73  
Омск (3812)21-46-40  
Орел (4862)44-53-42  
Оренбург (3532)37-68-04  
Пенза (8412)22-31-16  
Казахстан (772)734-952-31

Пермь (342)205-81-47  
Ростов-на-Дону (863)308-18-15  
Рязань (4912)46-61-64  
Самара (846)206-03-16  
Санкт-Петербург (812)309-46-40  
Саратов (845)249-38-78  
Севастополь (8692)22-31-93  
Симферополь (3652)67-13-56  
Смоленск (4812)29-41-54  
Сочи (862)225-72-31  
Ставрополь (8652)20-65-13  
Таджикистан (992)427-82-92-69

Сургут (3462)77-98-35  
Тверь (4822)63-31-35  
Томск (3822)98-41-53  
Тула (4872)74-02-29  
Тюмень (3452)66-21-18  
Ульяновск (8422)24-23-59  
Уфа (347)229-48-12  
Хабаровск (4212)92-98-04  
Челябинск (351)202-03-61  
Череповец (8202)49-02-64  
Ярославль (4852)69-52-93

Единый адрес для всех регионов: [bya@nt-rt.ru](mailto:bya@nt-rt.ru) | | [www.bray.nt-rt.ru](http://www.bray.nt-rt.ru)

# Краны шаровые резьбовые серии S20/FS20

Flow-Tek's Series S20 ball valves offer a compact, one piece body design. The one piece body supplies maximum structural strength while minimizing the number of potential leak paths.

These valves feature quarter turn operation, bottom entry blowout proof stems and low operating torque. Live-loaded, self-adjusting stem seals automatically adjust to compensate for changes in wear and temperature. Series S20 valves are available in both standard and fire safe versions.

## FS20 Fire Safe - Certified to API 607

Series FS20 valves have been thoroughly fire tested and meet these latest standards. Additionally, the adjustable graphite stem packing provides reduced torque and a very high cycle life.

Other features include replaceable seats and seals, stainless steel safety latch handles and high quality investment cast bodies. All bodies are marked with a foundry heat number for full traceability. An optional oval handle is available.



Optional Fire Safe, API 607 Certified

Size	Pressure Rating	Steam Rating	Temperature Range	End Connections	Body Material
1/4" to 2" 8mm to 50mm	2000 psi WOG 138 bar	150 psi WSP 10.3 bar	-50°F to +450°F -46°C to +232°C	Threaded - NPT	Stainless Steel

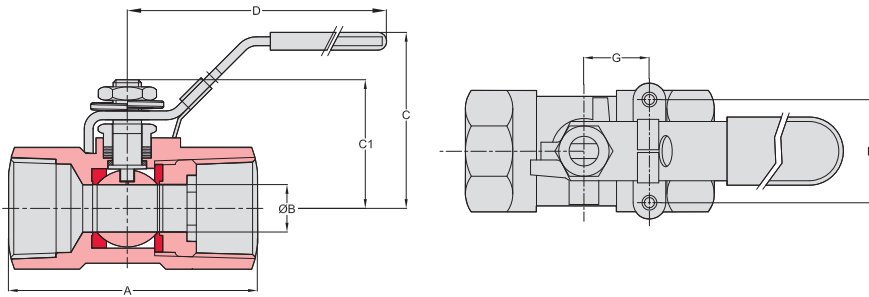

**Dimensions**

Size ins. mm	A	øB	C	C1	D	G	H	S	Cv	Weight lbs. kg
1/4 8	2.32 59	0.36 9.2	1.57 40	1.18 30	3.59 91	.49 12.5	1.12 28.5	1.02 26	5.5	0.198 .09
3/8 10	2.32 59	0.36 9.2	1.57 40	1.18 30	3.59 91	.49 12.5	1.12 28.5	1.02 26	5.5	0.309 .14
1/2 15	2.64 67	0.36 9.2	1.57 40	1.18 30	3.59 91	.49 12.5	1.12 28.5	1.02 26	5.5	0.595 .27
3/4 20	2.80 71	0.49 12.5	1.73 44	1.38 35	4.06 103	.49 12.5	1.12 28.5	1.26 32	10	0.705 .32
1 25	3.31 84	0.60 15	2.36 60	1.57 40	4.37 111	0.83 21	1.37 34.8	1.56 39.5	16.3	1.389 .63
1 1/4 32	3.70 94	0.79 20	2.56 65	1.96 50	4.96 126	.83 21	1.37 34.8	1.97 50	30	2.667 1.21
1 1/2 40	3.94 100	0.98 25	2.67 68	2.36 60	4.96 126	0.89 22.5	1.37 34.8	2.17 55	37	2.998 1.36
2 50	4.49 114	1.26 32	3.11 79	2.68 68	6.06 154	0.92 23.5	1.5 38.1	2.76 70	60	3.946 1.79

All Series S20 valves comply with NACE MR0175.  
 All valves are tested in accordance with: MSS-SP 72.  
 Vacuum Service to: 29 inches Hg. gauge.

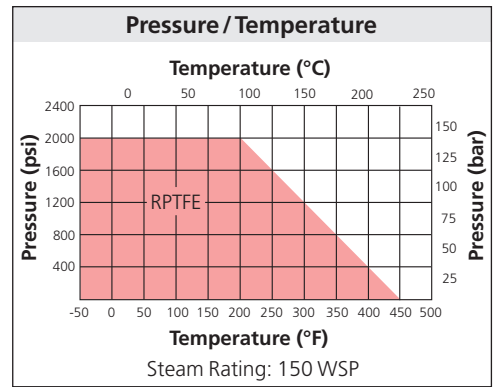

**Fire Safe:** Flow-Tek's Model FS20 valves with graphite stem packing and body seal are certified fire safe. In the event of a fire, after heat destroys the primary resilient seat, the ball makes contact with the secondary metal seat, forming a secure seal. The graphite body seal prevents external leakage. The graphite live-loaded stem packing prevents stem leakage. All valves have anti-static devices as standard, grounding ball and stem to body.

**Components & Materials Standard S20**

Item	Description	Material	Qty.
1	Handle Sleeve	PVC Vinyl	1
2	Handle	304	1
3	Locking	304	1
4	Stem Nut	304	1
5	Spring Washer	304	1
6	Stem	304/316	1
7	Gland Nut	304	1
8	Stem Packing	RPTFE	1
9	Thrust Washer	RPTFE	1
10	Body	CF8/CF8M	1
11	Seat A	RPTFE	1
12	Ball	CF8/CF8M	1
13	Seat B	FPTFE	1
14	Insert	304/316	1
15	Secure Pin	304	1

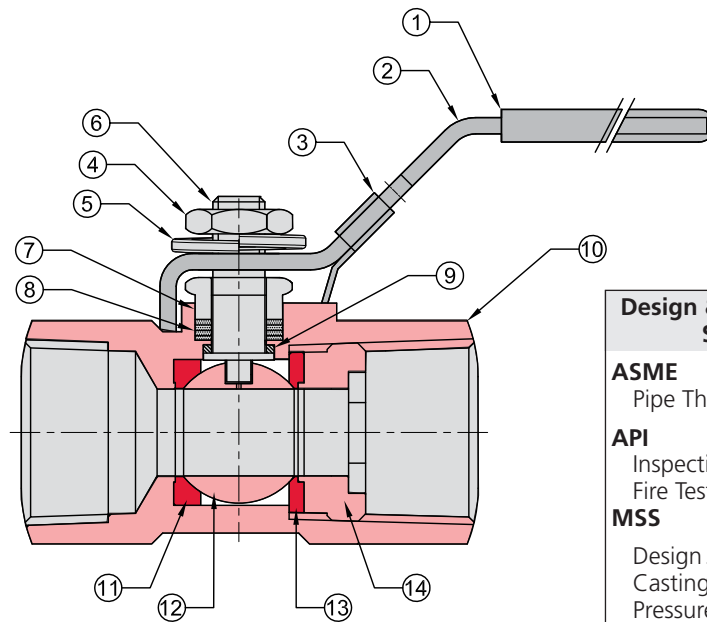

**Design & Manufacturing Standards**

**ASME**  
 Pipe Threads ..... B1.20.1

**API**  
 Inspection/Testing ..... 598  
 Fire Testing ..... 607

**MSS**  
 Design ..... SP110  
 Castings ..... SP55  
 Pressure Testing ..... SP61

**NACE**  
 H2S SSC ..... MR0175

\*Fire Safe valves / Non Fire Safe valves.

Архангельск (8182)63-90-72  
Астана (7172)727-132  
Астрахань (8512)99-46-04  
Барнаул (3852)73-04-60  
Белгород (4722)40-23-64  
Брянск (4832)59-03-52  
Владивосток (423)249-28-31  
Волгоград (844)278-03-48  
Вологда (8172)26-41-59  
Воронеж (473)204-51-73  
Екатеринбург (343)384-55-89  
Иваново (4932)77-34-06  
Ижевск (3412)26-03-58  
Иркутск (395)279-98-46  
Казань (843)206-01-48  
Калининград (4012)72-03-81  
Калуга (4842)92-23-67  
Кемерово (3842)65-04-62  
Киров (8332)68-02-04  
Краснодар (861)203-40-90  
Красноярск (391)204-63-61  
Курск (4712)77-13-04  
Липецк (4742)52-20-81  
Киргизия (996)312-96-26-47  
Магнитогорск (3519)55-03-13  
Москва (495)268-04-70  
Мурманск (8152)59-64-93  
Набережные Челны (8552)20-53-41  
Нижний Новгород (831)429-08-12  
Новокузнецк (3843)20-46-81  
Новосибирск (383)227-86-73  
Омск (3812)21-46-40  
Орел (4862)44-53-42  
Оренбург (3532)37-68-04  
Пенза (8412)22-31-16  
Казахстан (772)734-952-31  
Пермь (342)205-81-47  
Ростов-на-Дону (863)308-18-15  
Рязань (4912)46-61-64  
Самара (846)206-03-16  
Санкт-Петербург (812)309-46-40  
Саратов (845)249-38-78  
Севастополь (8692)22-31-93  
Симферополь (3652)67-13-56  
Смоленск (4812)29-41-54  
Сочи (862)225-72-31  
Ставрополь (8652)20-65-13  
Таджикистан (992)427-82-92-69  
Сургут (3462)77-98-35  
Тверь (4822)63-31-35  
Томск (3822)98-41-53  
Тула (4872)74-02-29  
Тюмень (3452)66-21-18  
Ульяновск (8422)24-23-59  
Уфа (347)229-48-12  
Хабаровск (4212)92-98-04  
Челябинск (351)202-03-61  
Череповец (8202)49-02-64  
Ярославль (4852)69-52-93

**Единый адрес для всех регионов: [bya@nt-rt.ru](mailto:bya@nt-rt.ru) | | [www.bray.nt-rt.ru](http://www.bray.nt-rt.ru)**