

3-составные шаровые краны серии DM7000/DM8000

Технические характеристики



Архангельск (8182)63-90-72
Астана (7172)727-132
Астрахань (8512)99-46-04
Барнаул (3852)73-04-60
Белгород (4722)40-23-64
Брянск (4832)59-03-52
Владивосток (423)249-28-31
Волгоград (844)278-03-48
Вологда (8172)26-41-59
Воронеж (473)204-51-73
Екатеринбург (343)384-55-89
Иваново (4932)77-34-06

Ижевск (3412)26-03-58
Иркутск (395)279-98-46
Казань (843)206-01-48
Калининград (4012)72-03-81
Калуга (4842)92-23-67
Кемерово (3842)65-04-62
Киров (8332)68-02-04
Краснодар (861)203-40-90
Красноярск (391)204-63-61
Курск (4712)77-13-04
Липецк (4742)52-20-81
Киргизия (996)312-96-26-47

Магнитогорск (3519)55-03-13
Москва (495)268-04-70
Мурманск (8152)59-64-93
Набережные Челны (8552)20-53-41
Нижний Новгород (831)429-08-12
Новокузнецк (3843)20-46-81
Новосибирск (383)227-86-73
Омск (3812)21-46-40
Орел (4862)44-53-42
Оренбург (3532)37-68-04
Пенза (8412)22-31-16
Казахстан (772)734-952-31

Пермь (342)205-81-47
Ростов-на-Дону (863)308-18-15
Рязань (4912)46-61-64
Самара (846)206-03-16
Санкт-Петербург (812)309-46-40
Саратов (845)249-38-78
Севастополь (8692)22-31-93
Симферополь (3652)67-13-56
Смоленск (4812)29-41-54
Сочи (862)225-72-31
Ставрополь (8652)20-65-13
Таджикистан (992)427-82-92-69

Сургут (3462)77-98-35
Тверь (4822)63-31-35
Томск (3822)98-41-53
Тула (4872)74-02-29
Тюмень (3452)66-21-18
Ульяновск (8422)24-23-59
Уфа (347)229-48-12
Хабаровск (4212)92-98-04
Челябинск (351)202-03-61
Череповец (8202)49-02-64
Ярославль (4852)69-52-93

Единый адрес для всех регионов: bya@nt-rt.ru | | www.bray.nt-rt.ru



3-составные шаровые краны серии DM7000/DM8000

1/2" - 2" (15mm - 50mm)

DM7000 - SS | DM8000 - CS

1000 psi WOG

DM7000/DM8000 DIRECT MOUNT SERIES BALL VALVES

The Series DM7000/DM8000 design is based on the series 7000/8000 with extensive interchangeability of the majority of the parts between the two series.

In addition to all the features and options of the Series 7000/8000, the direct mount valve design reduces the number of parts, the overall envelope dimensions and hysteresis between the ball and actuator. The cast top flange ensures direct actuator mounting and is designed to the ISO 5211 standard. Actuation equipment can be easily and safely removed while the valve is under full line pressure. The integrated extension is equipped with a 1/8" NPT threaded vent hole for pressure relief or for fugitive emissions monitoring while in service.

Direct Mount valves are offered with the full range of interchangeable end connections including threaded, socket weld, butt weld, ASME Class 150 flanged and extended weld in place. These are the same end connections found in the standard 7000/8000 valves.

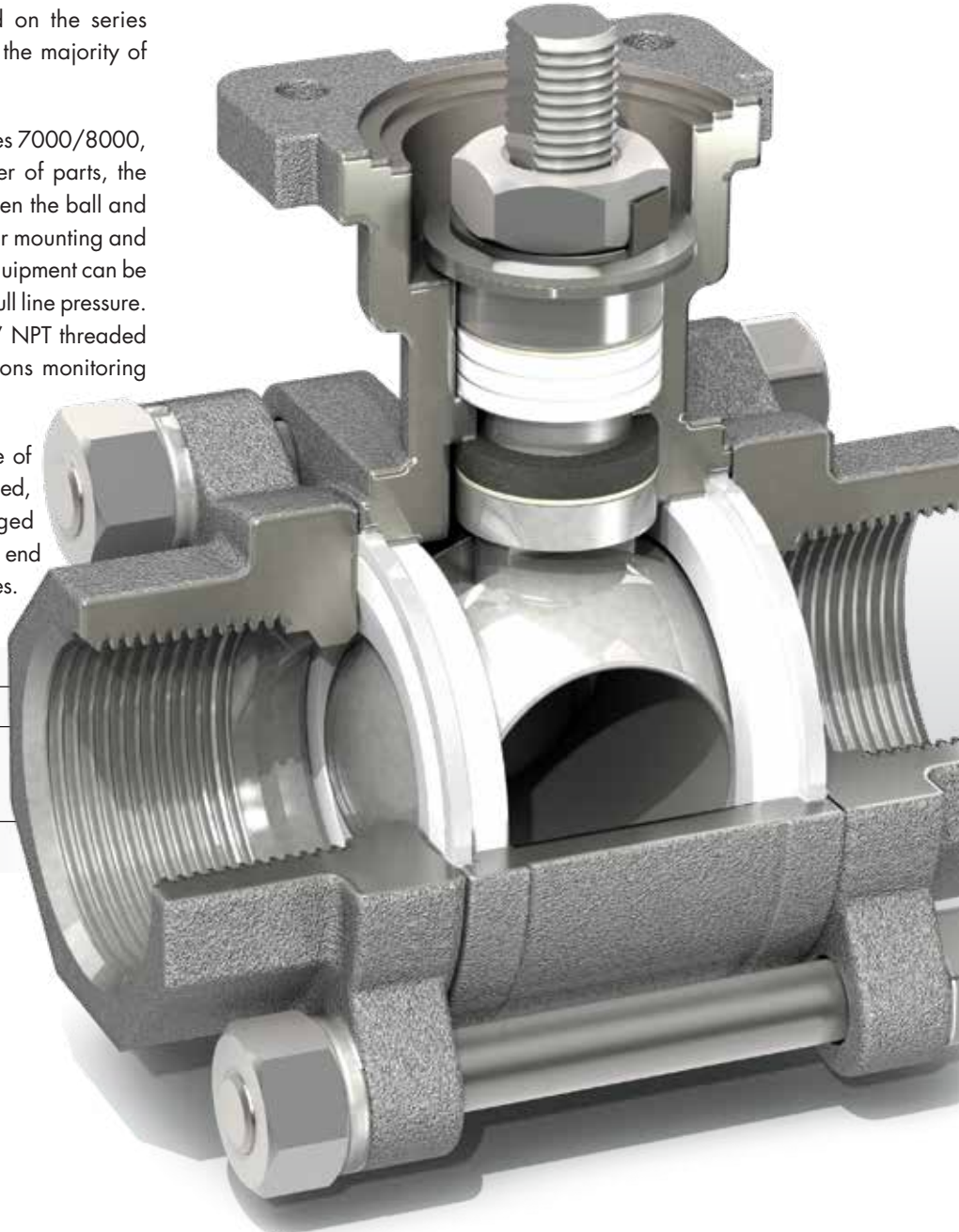

Body	3 Piece
Full Port	1/2" - 2" (15mm - 50mm)
Materials	Stainless Steel CF8M*, Carbon Steel WCB & Special Alloys
Pressure Ratings	1000 WOG

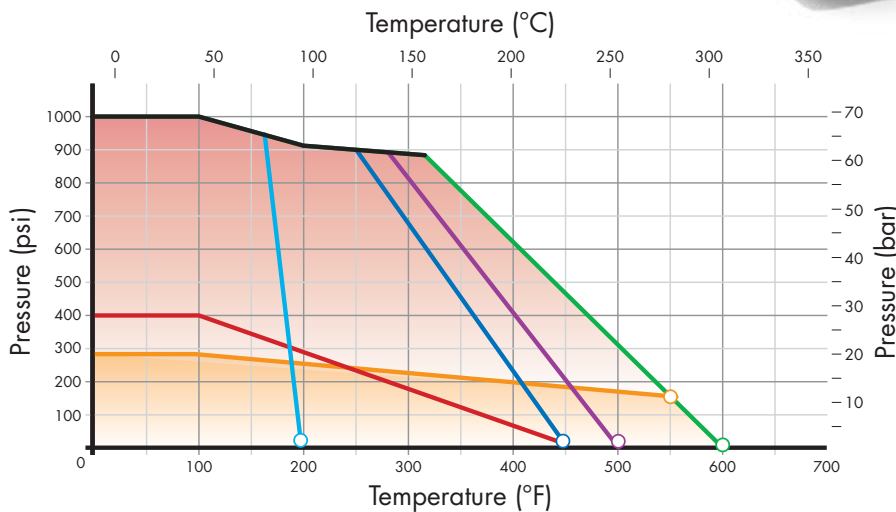

- 1/4" - 4" Valves: UHMWPE
- 1/4" - 4" Valves: RPTFE/TFM
- 1/4" - 4": 50/50 SS Filled TFE
- 1/4" - 4" Valves: Tek-Fil
- 6"-12" Butt Weld Valves: RPTFE
- ASME Class 150 Flanged

NOTE: Series 8000 carbon steel valves are limited to -20°F.
Series 7000 stainless steel valves are limited to -50°F.

SPECIAL OPTIONS/SERVICES

- Cavity Fillers
- Deadman Handles
- V Port Balls
- Vented Balls
- Chlorine Service
- Polished Internals
- Special Cleaning
- Silicone Free
- Media Containment Units (MCU's)

AVAILABLE END CAP CONNECTIONS

- Threaded End
- Socket Weld End
- Extended Socket Weld End
- Butt Weld End (Schedule 40)
- Extended Butt Weld End (Schedule 40)
- Flanged End (ASME Class 150)



COMPONENTS AND MATERIALS

ITEM/NAME	STAINLESS STEEL	CARBON STEEL	QTY.
1 Body	ASTM A351 Gr CF8M	ASTM A216 Gr WCB	1
2 End Cap*	ASTM A351 Gr CF8M*	ASTM A216 Gr WCB	2
3 Ball	ASTM A351 Gr CF8M		1
4 Seat	15% RPTFE		2 •
5 Stem	ASTM A479 Type 316		1
6 Body Seal	TFM		2 •
7 Spring Washer	SS304		4
8 Body Nut	SS304		4
9 Body Bolt / Stud	SS304		4

* Weld Ends use CF3M

ITEM/NAME	STAINLESS STEEL	CARBON STEEL	QTY.
10 Anti-Static Device (not shown)	SS316		2
11 Packing/Thrust Washer Protector	PEEK		2 •
12 Thrust Washer	TEK-FIL®		1 •
14 Stem Packing	15% RPTFE		3 •
15 Packing Gland Sleeve	SS304		1
18 Belleville Washer	SS301		2
19 Tab Lock Washer	SS304		1
26 Stem Nut	SS304		1
40 Plug (optional)	SS304		1

• Recommended spare parts that are available as a packaged repair kit

SERIES DM7000 & DM8000 DIMENSIONS 1/2" – 2" VALVES (15mm - 50mm)

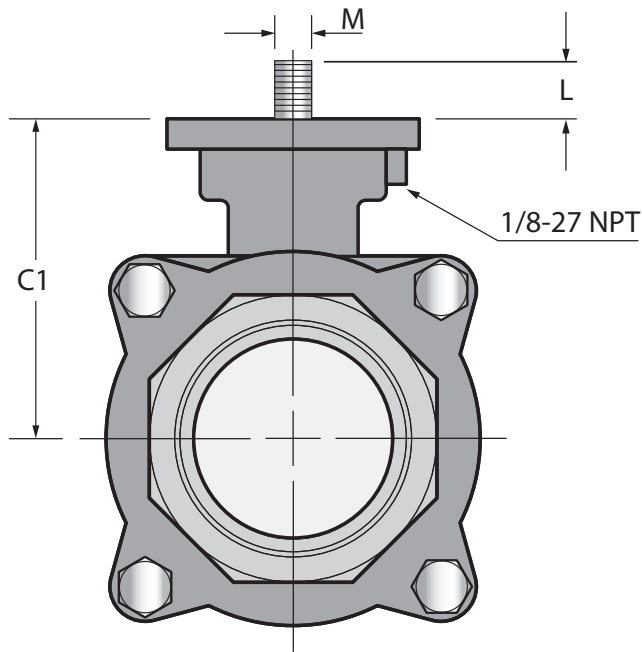

For further dimensional data and flow coefficients refer to the Series 7000/8000 literature available at www.Flow-Tek.com.

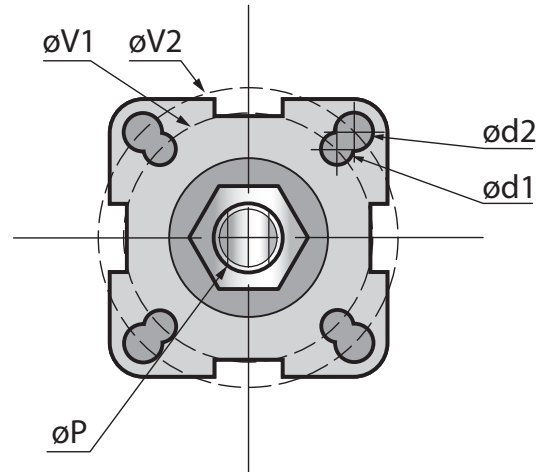

DIMENSIONS – Models DM7000 (SS) / DM8000 (CS)

	SIZE	C1	M	L	øP	ød1	øV1	ød2	øV2	Weight
INCHES	1/2	1.92	0.25	0.26	0.37	0.22	1.65	0.28	1.97	1.62
	3/4	1.99	0.25	0.26	0.37	0.22	1.65	0.28	1.97	2.20
	1	2.41	0.31	0.40	0.43	-	-	0.28	1.97	3.00
	1¼	2.56	0.31	0.38	0.43	-	-	0.28	1.97	4.70
	1½	3.04	0.37	0.43	0.62	-	-	0.35	2.76	7.20
	2	3.38	0.37	0.43	0.62	-	-	0.35	2.76	10.1
MILLIMETERS	15	48.85	6.3	6.7	9.3	5.5	42	7	50	0.734
	20	50.55	6.3	6.7	9.3	5.5	42	7	50	1
	25	61.1	8	10.1	10.9	-	-	7	50	1.342
	32	65.1	8	9.6	10.9	-	-	7	50	2.13
	40	77.2	9.5	11	15.7	-	-	9	70	3.275
	50	85.95	9.5	11	15.7	-	-	9	70	4.975

SPECIFICATIONS

Valve Sizes 1/2" through 2" (15mm - 50mm)

Design meets MSS-SP-110.

Threaded End Connections meet ASME B1.20.1 NPT.

Socket Weld End Connections meet ASME B16.11.

Butt Weld End (sch 40) Connections meet MSS SP-72 /ASME B16.25.

Flanged End Connections meet ASME Class 150.

Valve body and end cap connections are high quality investment cast and solution annealed/normalized. Body and end cap wall thickness meets ASME B16.34.

Valve stems are blow-out proof for maximum safety and meet ASME B16.34 specification.

All valves are factory tested to MSS SP-72 and API 598.

Архангельск (8182)63-90-72
Астана (7172)727-132
Астрахань (8512)99-46-04
Барнаул (3852)73-04-60
Белгород (4722)40-23-64
Брянск (4832)59-03-52
Владивосток (423)249-28-31
Волгоград (844)278-03-48
Вологда (8172)26-41-59
Воронеж (473)204-51-73
Екатеринбург (343)384-55-89
Иваново (4932)77-34-06
Ижевск (3412)26-03-58
Иркутск (395)279-98-46
Казань (843)206-01-48
Калининград (4012)72-03-81
Калуга (4842)92-23-67
Кемерово (3842)65-04-62
Киров (8332)68-02-04
Краснодар (861)203-40-90
Красноярск (391)204-63-61
Курск (4712)77-13-04
Липецк (4742)52-20-81
Киргизия (996)312-96-26-47
Магнитогорск (3519)55-03-13
Москва (495)268-04-70
Мурманск (8152)59-64-93
Набережные Челны (8552)20-53-41
Нижний Новгород (831)429-08-12
Новокузнецк (3843)20-46-81
Новосибирск (383)227-86-73
Омск (3812)21-46-40
Орел (4862)44-53-42
Оренбург (3532)37-68-04
Пенза (8412)22-31-16
Казахстан (772)734-952-31
Пермь (342)205-81-47
Ростов-на-Дону (863)308-18-15
Рязань (4912)46-61-64
Самара (846)206-03-16
Санкт-Петербург (812)309-46-40
Саратов (845)249-38-78
Севастополь (8692)22-31-93
Симферополь (3652)67-13-56
Смоленск (4812)29-41-54
Сочи (862)225-72-31
Ставрополь (8652)20-65-13
Таджикистан (992)427-82-92-69
Сургут (3462)77-98-35
Тверь (4822)63-31-35
Томск (3822)98-41-53
Тула (4872)74-02-29
Тюмень (3452)66-21-18
Ульяновск (8422)24-23-59
Уфа (347)229-48-12
Хабаровск (4212)92-98-04
Челябинск (351)202-03-61
Череповец (8202)49-02-64
Ярославль (4852)69-52-93

Единый адрес для всех регионов: bya@nt-rt.ru | | www.bray.nt-rt.ru