

# Задвижки шиберно-ножевые односторонние серии 940

## Технические характеристики



Архангельск (8182)63-90-72  
Астана (7172)727-132  
Астрахань (8512)99-46-04  
Барнаул (3852)73-04-60  
Белгород (4722)40-23-64  
Брянск (4832)59-03-52  
Владивосток (423)249-28-31  
Волгоград (844)278-03-48  
Вологда (8172)26-41-59  
Воронеж (473)204-51-73  
Екатеринбург (343)384-55-89  
Иваново (4932)77-34-06

Ижевск (3412)26-03-58  
Иркутск (395)279-98-46  
Казань (843)206-01-48  
Калининград (4012)72-03-81  
Калуга (4842)92-23-67  
Кемерово (3842)65-04-62  
Киров (8332)68-02-04  
Краснодар (861)203-40-90  
Красноярск (391)204-63-61  
Курск (4712)77-13-04  
Липецк (4742)52-20-81  
Киргизия (996)312-96-26-47

Магнитогорск (3519)55-03-13  
Москва (495)268-04-70  
Мурманск (8152)59-64-93  
Набережные Челны (8552)20-53-41  
Нижний Новгород (831)429-08-12  
Новокузнецк (3843)20-46-81  
Новосибирск (383)227-86-73  
Омск (3812)21-46-40  
Орел (4862)44-53-42  
Оренбург (3532)37-68-04  
Пенза (8412)22-31-16  
Казахстан (772)734-952-31

Пермь (342)205-81-47  
Ростов-на-Дону (863)308-18-15  
Рязань (4912)46-61-64  
Самара (846)206-03-16  
Санкт-Петербург (812)309-46-40  
Саратов (845)249-38-78  
Севастополь (8692)22-31-93  
Симферополь (3652)67-13-56  
Смоленск (4812)29-41-54  
Сочи (862)225-72-31  
Ставрополь (8652)20-65-13  
Таджикистан (992)427-82-92-69

Сургут (3462)77-98-35  
Тверь (4822)63-31-35  
Томск (3822)98-41-53  
Тула (4872)74-02-29  
Тюмень (3452)66-21-18  
Ульяновск (8422)24-23-59  
Уфа (347)229-48-12  
Хабаровск (4212)92-98-04  
Челябинск (351)202-03-61  
Череповец (8202)49-02-64  
Ярославль (4852)69-52-93

Единый адрес для всех регионов: [bya@nt-rt.ru](mailto:bya@nt-rt.ru) | [www.bray.nt-rt.ru](http://www.bray.nt-rt.ru)

---

# Задвижки шиберно-ножевые односторонние серии 940

2" to 24" 150psi (10bar)  
30" to 36" 100psi (7bar)



## FEATURES & BENEFITS

### DESIGN FEATURES

Engineered for general purpose on/off service and isolation of clean, dirty, corrosive, abrasive, viscous and high temperature media.

- 1 Topworks designed for easy, quick conversion between manual and pneumatic actuation. Manual valves include a lubricant injection port for continuous, smooth operation with minimal maintenance.
- 2 Clevis design and horizontal bolting stabilizes gate ensuring proper alignment.
- 3 Standard multi-layer square packing provides exceptional gland sealing.
- 4 Optional energized quad seal packing for additional leak prevention.
- 5 Standard integral metal seat and optional replaceable zero leakage resilient seats.
- 6 Gate design ensures consistent alignment throughout the length of the stroke.
- 7 Unique body design with no dead pockets enables self-draining of valve.
- 8 Lugged body suitable for all mounting orientations including dead-end service.
- 9 Cast yoke superstructure ensures robustness in valve design for different operators/orientation.

### APPLICATIONS

- > Power
- > Mining
- > Pulp & Paper
- > Cement
- > Carbon Black
- > Chemical

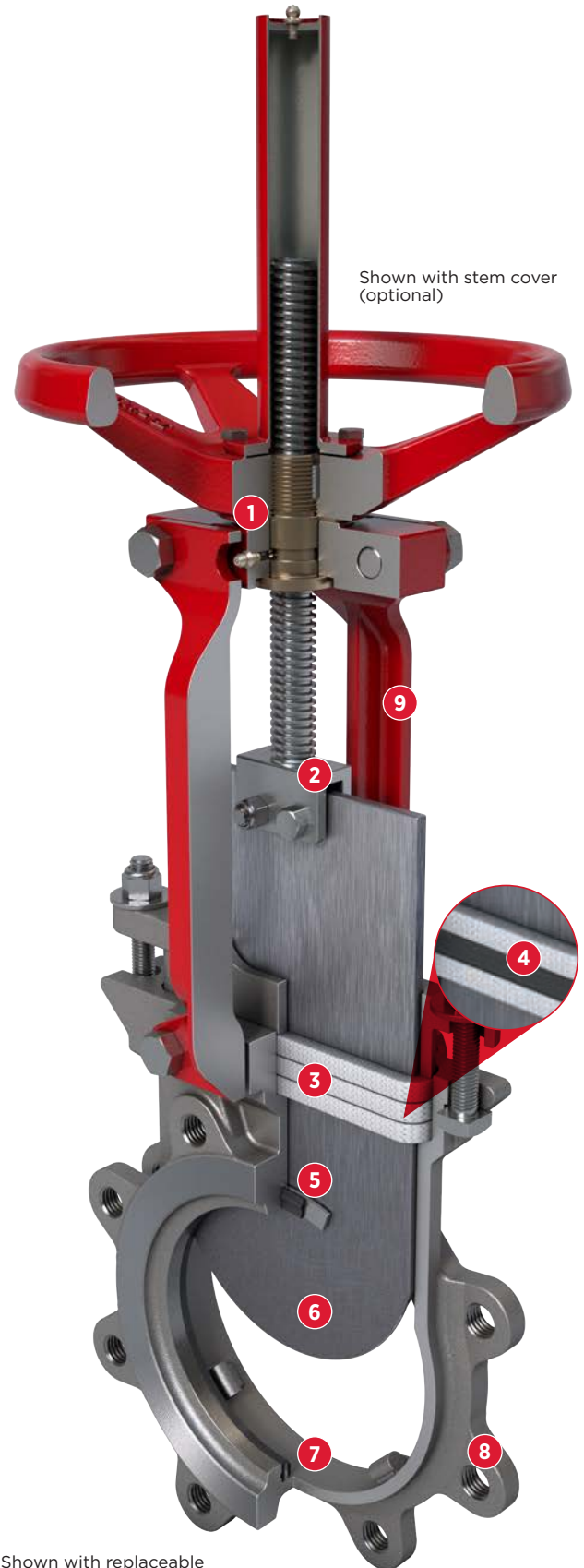

Shown with replaceable resilient seat (optional)

Series 940 Lug Style

# PACKING, SEAT & GATE OPTIONS

## TECHNICAL SPECIFICATIONS

<b>Size Range</b>	NPS 2 to 36 DN 50 to 900
<b>Body Style</b>	Single piece   Lug
<b>Pressure Rating</b>	2-24 150psi   30-36 100psi 50-600mm 10 bar   750-900mm 7 bar
<b>Drilling</b>	ASME B16.5 CL150 ASME B16.47 CL150
<b>Face to Face</b>	MSS SP-81
<b>Certification</b>	CE/PED, Canadian CRN
<b>Design Standard</b>	MSS SP-81
<b>Testing Standard</b>	MSS SP-151

## STANDARD CONSTRUCTION

<b>Body</b>	CF8 (304)	CF8M (316)
<b>Gate</b>	304	316
<b>Seat</b>	Integral	Integral
<b>Stem</b>	304	304
<b>Gland</b>	304	304
<b>Packing</b>	PTFE Impregnated Synthetic Fiber	PTFE Impregnated Synthetic Fiber
<b>Topworks</b>	CS	CS

\* Consult factory for Pressure Rating

## GATE OPTIONS

304, 316, 317 Stainless Steel
SAF 2507 Duplex
17-4PH Stainless Steel
Hastelloy® C
Monel®
Titanium

## BODY OPTIONS

Carbon Steel (WCB)
CF8 Stainless Steel
CF8M Stainless Steel
CF3M Stainless Steel
SAF 2205 Duplex
SAF 2507 Duplex

## PACKING MAXIMUM TEMPERATURE RANGE

<b>Pure PTFE</b>	500°F 260°C
<b>PTFE Impregnated Synthetic Fiber</b>	450°F 232°C
<b>PTFE w/Buna-N Quad Seal<sup>1</sup></b>	194°F 90°C
<b>PTFE w/Viton® Quad Seal<sup>1</sup></b>	392°F 200°C
<b>PTFE w/EPDM Quad Seal</b>	248°F 120°C
<b>PTFE w/Copper Wiper<sup>1</sup></b>	500°F 260°C
<b>Graphite</b>	1202°F 650°C

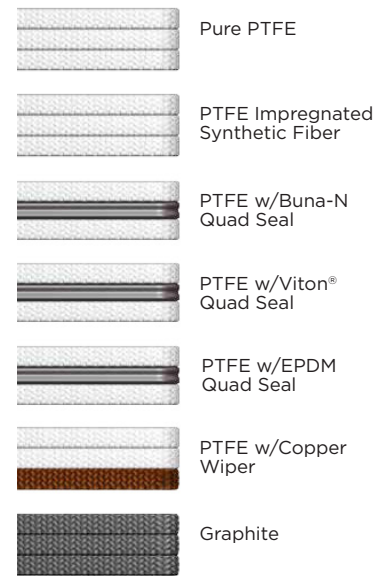

**NOTE** <sup>1</sup> Pure PTFE or PTFE Impregnated Synthetic Fiber can be used.

## SEAT OPTIONS

Standard integral metal seat and optional replaceable zero leakage resilient seat.



<b>Buna-N</b>	-34 to 194°F -36 to 90°C
<b>EPDM</b>	-65 to 248°F -54 to 120°C
<b>Viton®</b>	-15 to 392°F -26 to 200°C



<b>PTFE w/Viton Back-up Ring**</b>	-235 to 500°F -148 to 260°C
------------------------------------	--------------------------------

\*\* Allowable seat leakage as per MSS SP-151 metal seated valves

# MATERIALS OF CONSTRUCTION

## MATERIAL SPECIFICATIONS & PARTS CALLOUT

ITEM	DESCRIPTION	MATERIAL
1	Body	304 Stainless Steel
2	Gate	304 Stainless Steel
3	Packing Set	Synthetic Fibre PTFE Impregnated
4	Gland	304 Stainless Steel
5	Gland Bolt	304 Stainless Steel
6	Gland Washer	304 Stainless Steel
7	Gland Nut	316 Stainless Steel
8	Yoke	Carbon Steel
9	Mounting Bolt (Top)	304 Stainless Steel
10	Mounting Nut (Top)	316 Stainless Steel
11	Mounting Bolt (Bottom)	304 Stainless Steel
12	Spring Washer	304 Stainless Steel
13	Clevis	304 Stainless Steel
14	Stem	304 Stainless Steel
15	Clevis Bolt	304 Stainless Steel
16	Clevis Nut	316 Stainless Steel
17	Collar	Ductile Iron
18	Yoke Sleeve	Aluminum Bronze
19	Grease Nipple	Bronze
20	Thrust Washer	Aluminum Bronze
21	Hand Wheel	Cast Iron
22	Socket Screw	Carbon Steel

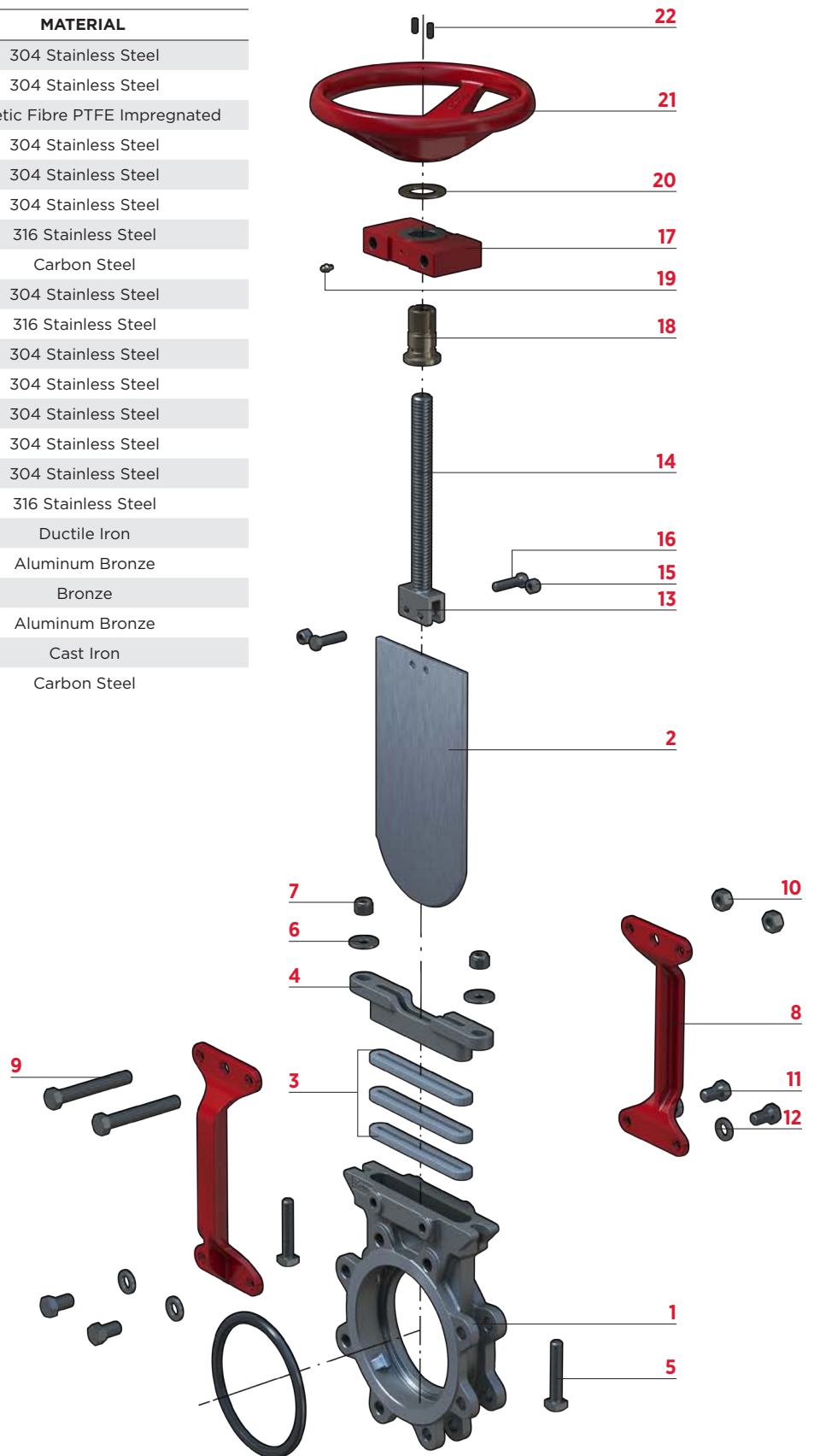

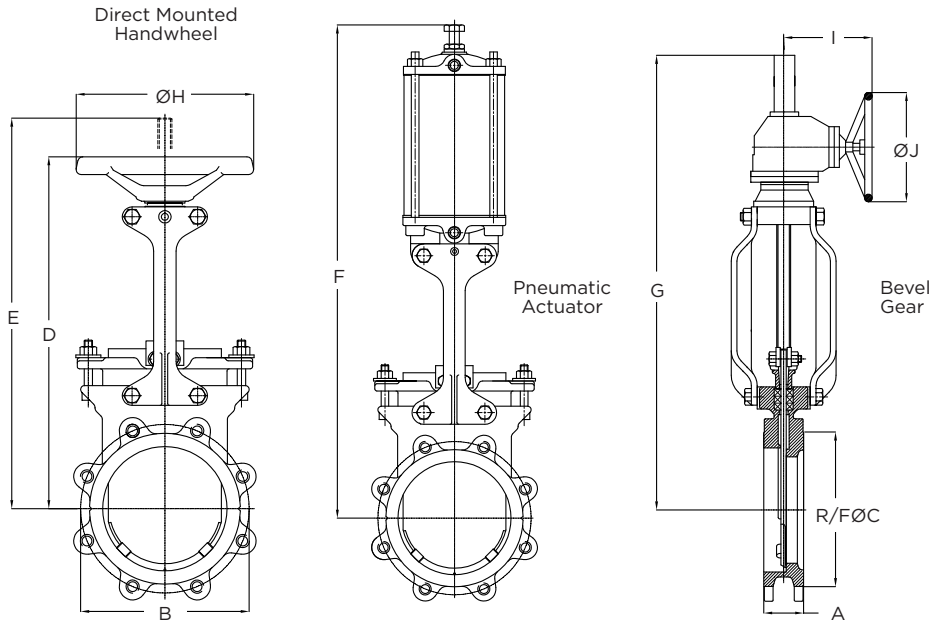

**NOTE**  
1 Consult factory for hydraulic and electric actuator dimensions.

DIMENSIONS (Inches)										
NPS	A	B*	R/FØC	D	E	F	G	ØH	I	ØJ
2	1.88	4.75	3.62	13.03	13.94	19.17	--	8.00	--	--
3	2.00	6.00	5.00	15.71	18.43	22.80	--	8.00	--	--
4	2.00	7.50	6.19	17.32	21.10	25.39	--	8.00	--	--
5	2.25	8.50	7.31	19.41	23.90	28.35	--	10.00	--	--
6	2.25	9.50	8.50	20.91	26.34	31.65	--	10.00	--	--
8	2.75	11.75	10.62	24.84	32.28	38.74	35.63	12.00	11.65	20.00
10	2.75	14.25	12.75	27.28	37.68	44.21	41.06	16.00	11.65	20.00
12	3.00	17.00	15.00	30.67	43.11	51.22	47.80	16.00	11.65	20.00
14	3.00	18.75	16.25	33.66	47.72	54.96	49.80	20.00	12.05	20.00
16	3.50	21.25	18.50	37.01	52.83	63.07	55.12	20.00	12.05	20.00
18	3.50	22.75	21.00	41.85	60.04	70.28	61.93	20.00	12.05	20.00
20	4.50	25.00	23.00	46.34	66.10	76.34	68.39	20.00	12.05	20.00
24	4.50	29.50	27.25	54.06	77.99	89.92	80.04	20.00	12.05	20.00
30	Contact factory for dimensions									
36	Contact factory for dimensions									

WEIGHT (lbs)		
HAND WHEEL	PNEUMATIC ACTUATOR	GEAR OPERATOR
20	35	--
29	40	--
31	53	--
49	77	--
51	84	--
77	121	106
117	212	183
168	313	209
265	410	282
357	496	364
474	600	474
750	805	606
893	1054	959
Contact factory		
Contact factory		

DIMENSIONS (Millimeters)										
DN	A	B*	R/FØC	D	E	F	G	ØH	I	ØJ
50	48	120.7	92	331	354	487	--	203	--	--
80	51	152.4	127	399	468	579	--	203	--	--
100	51	190.5	158	440	536	645	--	203	--	--
125	57	215.9	186	493	607	720	--	254	--	--
150	57	241.3	216	531	669	804	--	254	--	--
200	70	295.5	270	631	820	984	905	305	296	508
250	70	362.0	324	693	957	1123	1043	406	296	508
300	76	431.8	375	779	1095	1301	1214	406	296	508
350	76	476.3	413	855	1212	1396	1265	508	296	508
400	89	539.8	470	940	1342	1602	1400	508	296	508
450	89	577.9	533	1063	1525	1785	1573	508	296	508
500	114	635.0	585	1177	1679	1939	1737	508	296	508
600	114	749.3	692	1373	1981	2284	2033	508	296	508
750	Contact factory for dimensions									
900	Contact factory for dimensions									

WEIGHT (kg)		
9	16	--
13	18	--
14	24	--
22	35	--
23	38	--
35	55	48
53	96	83
76	142	95
120	186	128
162	225	165
215	272	215
340	365	275
405	478	435
Contact factory		
Contact factory		

Dimensions are approximate and subject to change. Consult factory for certified drawings.

\* In conformance with ASME B16.5, Class 150 for sizes NPS 2 (DN50) through NPS 24 (DN600) and per ASME B16.47 Series A for sizes > NPS 24.

**OPTIONS & ACCESSORIES**

**ACTUATOR OPTIONS | SHOWN IN RED**



Direct Mounted Handwheel



Bevel Gear Operator



Double Acting Pneumatic Actuator



Hydraulic Actuator

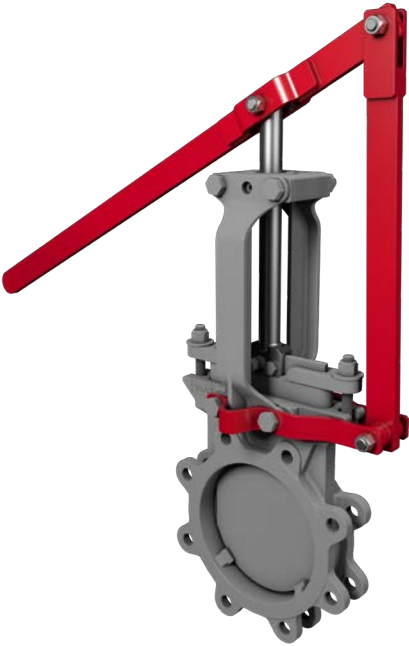

Lever



Electric Actuator

# OPTIONS & ACCESSORIES

ADDITIONAL ACCESSORIES | SHOWN IN RED



Deflection Cone

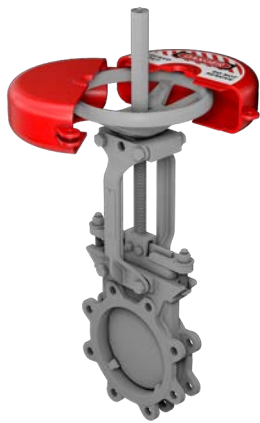

Handwheel Lock Out



Pinned Lockout Open & Closed



Pneumatic Failsafe

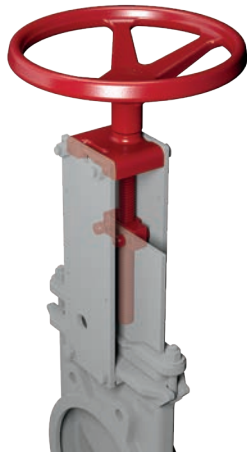

Non-Rising Stem



Gate Guard



Manual Override



Chain Wheel



Mechanical Limit Switch



Positioner



Proximity Sensor



Архангельск (8182)63-90-72  
Астана (7172)727-132  
Астрахань (8512)99-46-04  
Барнаул (3852)73-04-60  
Белгород (4722)40-23-64  
Брянск (4832)59-03-52  
Владивосток (423)249-28-31  
Волгоград (844)278-03-48  
Вологда (8172)26-41-59  
Воронеж (473)204-51-73  
Екатеринбург (343)384-55-89  
Иваново (4932)77-34-06  
Ижевск (3412)26-03-58  
Иркутск (395)279-98-46  
Казань (843)206-01-48  
Калининград (4012)72-03-81  
Калуга (4842)92-23-67  
Кемерово (3842)65-04-62  
Киров (8332)68-02-04  
Краснодар (861)203-40-90  
Красноярск (391)204-63-61  
Курск (4712)77-13-04  
Липецк (4742)52-20-81  
Киргизия (996)312-96-26-47  
Магнитогорск (3519)55-03-13  
Москва (495)268-04-70  
Мурманск (8152)59-64-93  
Набережные Челны (8552)20-53-41  
Нижний Новгород (831)429-08-12  
Новокузнецк (3843)20-46-81  
Новосибирск (383)227-86-73  
Омск (3812)21-46-40  
Орел (4862)44-53-42  
Оренбург (3532)37-68-04  
Пенза (8412)22-31-16  
Казахстан (772)734-952-31  
Пермь (342)205-81-47  
Ростов-на-Дону (863)308-18-15  
Рязань (4912)46-61-64  
Самара (846)206-03-16  
Санкт-Петербург (812)309-46-40  
Саратов (845)249-38-78  
Севастополь (8692)22-31-93  
Симферополь (3652)67-13-56  
Смоленск (4812)29-41-54  
Сочи (862)225-72-31  
Ставрополь (8652)20-65-13  
Таджикистан (992)427-82-92-69  
Сургут (3462)77-98-35  
Тверь (4822)63-31-35  
Томск (3822)98-41-53  
Тула (4872)74-02-29  
Тюмень (3452)66-21-18  
Ульяновск (8422)24-23-59  
Уфа (347)229-48-12  
Хабаровск (4212)92-98-04  
Челябинск (351)202-03-61  
Череповец (8202)49-02-64  
Ярославль (4852)69-52-93

Единый адрес для всех регионов: [bya@nt-rt.ru](mailto:bya@nt-rt.ru) | | [www.bray.nt-rt.ru](http://www.bray.nt-rt.ru)