

# Задвижки шибберно-ножевые двусторонние серии 752

## Технические характеристики



Архангельск (8182)63-90-72  
Астана (7172)727-132  
Астрахань (8512)99-46-04  
Барнаул (3852)73-04-60  
Белгород (4722)40-23-64  
Брянск (4832)59-03-52  
Владивосток (423)249-28-31  
Волгоград (844)278-03-48  
Вологда (8172)26-41-59  
Воронеж (473)204-51-73  
Екатеринбург (343)384-55-89  
Иваново (4932)77-34-06

Ижевск (3412)26-03-58  
Иркутск (395)279-98-46  
Казань (843)206-01-48  
Калининград (4012)72-03-81  
Калуга (4842)92-23-67  
Кемерово (3842)65-04-62  
Киров (8332)68-02-04  
Краснодар (861)203-40-90  
Красноярск (391)204-63-61  
Курск (4712)77-13-04  
Липецк (4742)52-20-81  
Киргизия (996)312-96-26-47

Магнитогорск (3519)55-03-13  
Москва (495)268-04-70  
Мурманск (8152)59-64-93  
Набережные Челны (8552)20-53-41  
Нижний Новгород (831)429-08-12  
Новокузнецк (3843)20-46-81  
Новосибирск (383)227-86-73  
Омск (3812)21-46-40  
Орел (4862)44-53-42  
Оренбург (3532)37-68-04  
Пенза (8412)22-31-16  
Казахстан (772)734-952-31

Пермь (342)205-81-47  
Ростов-на-Дону (863)308-18-15  
Рязань (4912)46-61-64  
Самара (846)206-03-16  
Санкт-Петербург (812)309-46-40  
Саратов (845)249-38-78  
Севастополь (8692)22-31-93  
Симферополь (3652)67-13-56  
Смоленск (4812)29-41-54  
Сочи (862)225-72-31  
Ставрополь (8652)20-65-13  
Таджикистан (992)427-82-92-69

Сургут (3462)77-98-35  
Тверь (4822)63-31-35  
Томск (3822)98-41-53  
Тула (4872)74-02-29  
Тюмень (3452)66-21-18  
Ульяновск (8422)24-23-59  
Уфа (347)229-48-12  
Хабаровск (4212)92-98-04  
Челябинск (351)202-03-61  
Череповец (8202)49-02-64  
Ярославль (4852)69-52-93

Единый адрес для всех регионов: [bya@nt-rt.ru](mailto:bya@nt-rt.ru) | [www.bray.nt-rt.ru](http://www.bray.nt-rt.ru)

**Задвижки  
шиберно-ножевые  
двусторонние серии 752**



# Series 752

## Bidirectional High Performance Slurry Valve

The Bray/VAAS Series 752 features a robust steel reinforced perimeter seat which provides bidirectional zero leakage shutoff.

The replaceable steel reinforced perimeter seat is mechanically retained between both halves of the two-piece bolted body for unsurpassed performance in the most demanding applications.

Shown with stem cover (optional).

- 1 Designed for easy, quick conversion between manual and pneumatic actuation. Featuring a lubricant injection port for continuous, smooth operation with minimal maintenance.
- 2 Clevis design and horizontal bolting stabilizes gate ensuring proper alignment.
- 3 Standard multi-layer square packing with energized Quad seal provides exceptional gland sealing.
- 4 Unrestricted flow path with minimal pressure drop achieved through full port valve design.
- 5 Deflection resistant gate design ensures consistent alignment for industry leading durability.
- 6 Replaceable steel reinforced elastomer perimeter seat ensures bidirectional zero leakage shutoff.
- 7 Two-piece bolted body for easy maintenance and seat replacement.

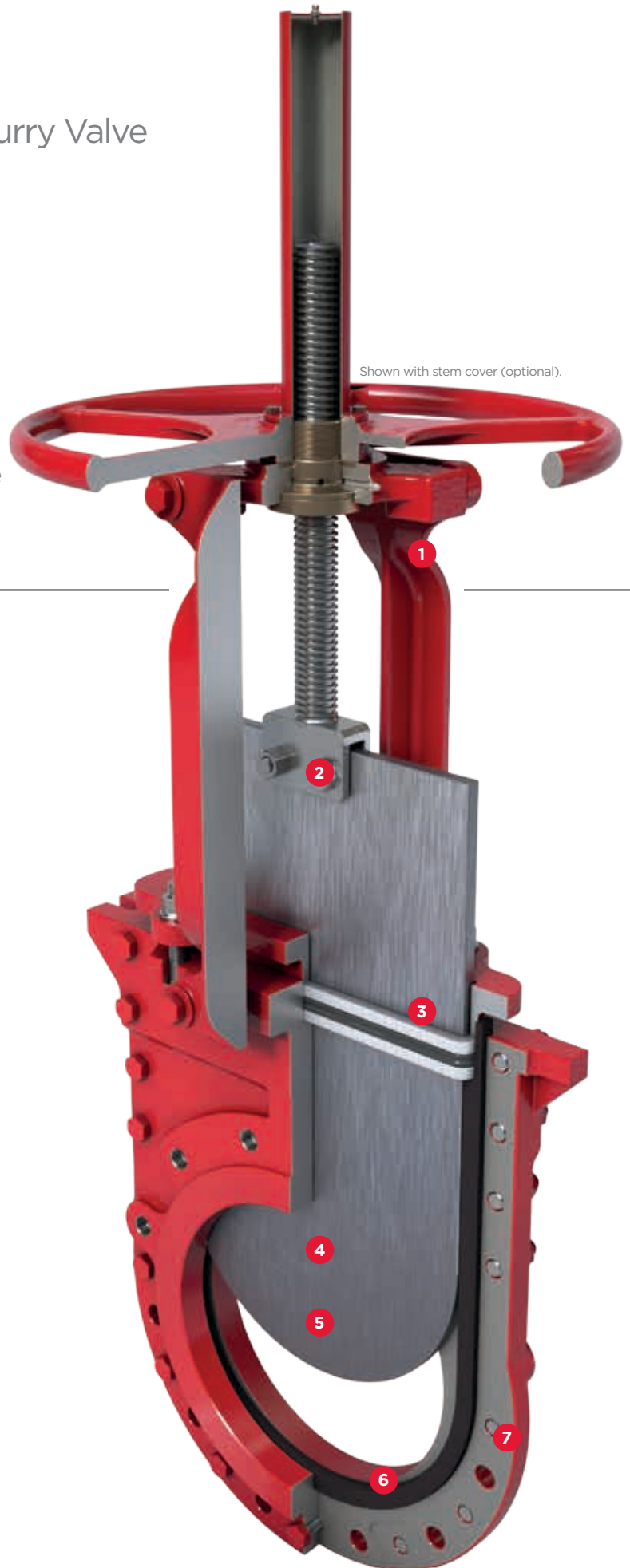

## Standard Construction

Body	Gate	Seat	Stem	Gland	Packing	Topworks
CF8	304	Buna-N	304	304	PTFE impregnated synthetic fiber w/Quad seal	Steel
CF8M	316	Buna-N	304	304	PTFE impregnated synthetic fiber w/Quad seal	Steel
WCB	304	Buna-N	304	WCB	PTFE impregnated synthetic fiber w/Quad seal	Steel
DI	304	Buna-N	304	WCB	PTFE impregnated synthetic fiber w/Quad seal	Steel

## Body Options

CF3M Stainless Steel
SAF 2205 Duplex
SAF 2507 Duplex

Additional material options may be available upon request. Consult factory for availability.

## Gate Options

304, 316, 317 Stainless Steel
SAF 2507 Duplex
SAF 2205 Duplex
17-4PH Stainless Steel
Hastelloy® C
Monel®

## Seat Options

Buna-N	-35°-194°F/-37°-90°C
EPDM	-65°-248°F/-54°-120°C
Viton®	-15°-392°F/-26°-200°C

## Actuator Options

Direct Mounted Handwheel Standard (2"-10")
Bevel Gear Standard (12"-24")
Pneumatic
Hydraulic
Electric

## Packing Options

PTFE impregnated synthetic fiber w/Quad seal	xx°C /xx°F
Elastomer Buna-N Quad	90°C/194°F
Viton Quad Seal	200°C/392°F

## Specifications & Standards

Size Range	2" to 24" (50 - 600mm)
Pressure Rating	150psi (10bar), 240psi (16bar), 300psi (20bar)
Body Style	Two-piece bolted (Wafer)

Design	MSS SP-81
Testing	MSS SP-81
Face-to-face	MSS SP-81 (150psi, 240psi models)
Certification	Canadian CRN
Drilling*	ASME B16.5 CL150

\*Additional drilling options available. Consult factory for availability.

## Dimensions

In. (mm)	A	B	C	D	E	F	G	H	I	J
2 (50)	1.89 48	4.76 121	3.62 92	13.33 379	15.87 403	7.99 203	18.41 510	--	--	--
3 (80)	2.01 51	6.02 153	5.00 127	15.71 419	18.49 470	7.99 203	21.84 575	--	--	--
4 (100)	2.01 51	7.52 191	6.18 157	17.73 510	22.73 577	10.00 254	25.24 701	--	--	--
6 (150)	2.24 57	9.53 242	8.50 216	22.36 622	28.74 730	11.77 299	33.41 903	--	--	--
8 (200)	2.76 70	11.77 299	10.63 270	24.95 703	35.28 896	15.98 406	40.06 1086	--	--	--
10 (250)	2.76 70	14.25 362	12.76 324	31.51 800	40.67 1033	15.98 406	50.07 1272	44.27 1125	12.05 306	20.00 508
12 (300)	2.99 76	17.01 432	14.76 375	--	--	--	55.72 1415	51.61 1311	12.05 306	20.00 508
14 (350)	2.99 76	18.74 476	16.26 413	--	--	--	59.99 1524	56.59 1437	12.05 306	20.00 508
16 (400)	3.50 89	21.26 540	18.50 470	--	--	--	70.46 1790	62.83 1596	12.99 330	20.00 508
18 (450)	3.50 89	22.76 578	21.00 534	--	--	--	77.64 1972	69.59 1768	12.99 330	20.00 508
20 (500)	4.49 114	25.00 635	22.99 584	--	--	--	86.14 2188	81.10 2060	13.46 342	20.00 508
24 (600)	4.49 114	29.53 750	27.24 692	--	--	--	99.08 2517	94.15 2392	13.46 342	20.00 508

Dimensions are approximate and subject to change. Consult factory for certified drawings.

## Weights

Size	in mm	2 50	3 80	4 100	6 150	8 200	10 250	12 300	14 350	16 400	18 450	20 500	24 600
HANDWHEEL	lb	26	42	49	84	132	174	--	--	--	--	--	--
	kg	12	19	22	38	60	79	--	--	--	--	--	--
PNEUMATIC ACTUATOR	lb	53	71	101	123	198	238	419	699	915	1124	1301	1532
	kg	24	32	46	56	90	108	190	317	415	510	590	695
GEAR OPERATOR	lb	--	--	--	--	188	243	298	463	650	864	1058	1290
	kg	--	--	--	--	85	110	135	210	295	392	480	585

\*Above table is applicable for 10 - 16 bar. For 20 bar consult factory.

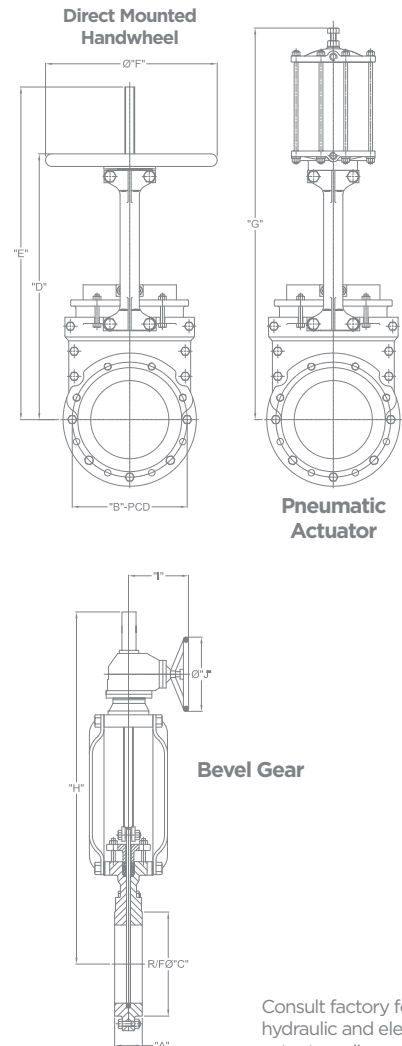

Consult factory for hydraulic and electric actuators dimensions.

Архангельск (8182)63-90-72  
Астана (7172)727-132  
Астрахань (8512)99-46-04  
Барнаул (3852)73-04-60  
Белгород (4722)40-23-64  
Брянск (4832)59-03-52  
Владивосток (423)249-28-31  
Волгоград (844)278-03-48  
Вологда (8172)26-41-59  
Воронеж (473)204-51-73  
Екатеринбург (343)384-55-89  
Иваново (4932)77-34-06  
Ижевск (3412)26-03-58  
Иркутск (395)279-98-46  
Казань (843)206-01-48  
Калининград (4012)72-03-81  
Калуга (4842)92-23-67  
Кемерово (3842)65-04-62  
Киров (8332)68-02-04  
Краснодар (861)203-40-90  
Красноярск (391)204-63-61  
Курск (4712)77-13-04  
Липецк (4742)52-20-81  
Киргизия (996)312-96-26-47  
Магнитогорск (3519)55-03-13  
Москва (495)268-04-70  
Мурманск (8152)59-64-93  
Набережные Челны (8552)20-53-41  
Нижний Новгород (831)429-08-12  
Новокузнецк (3843)20-46-81  
Новосибирск (383)227-86-73  
Омск (3812)21-46-40  
Орел (4862)44-53-42  
Оренбург (3532)37-68-04  
Пенза (8412)22-31-16  
Казахстан (772)734-952-31  
Пермь (342)205-81-47  
Ростов-на-Дону (863)308-18-15  
Рязань (4912)46-61-64  
Самара (846)206-03-16  
Санкт-Петербург (812)309-46-40  
Саратов (845)249-38-78  
Севастополь (8692)22-31-93  
Симферополь (3652)67-13-56  
Смоленск (4812)29-41-54  
Сочи (862)225-72-31  
Ставрополь (8652)20-65-13  
Таджикистан (992)427-82-92-69  
Сургут (3462)77-98-35  
Тверь (4822)63-31-35  
Томск (3822)98-41-53  
Тула (4872)74-02-29  
Тюмень (3452)66-21-18  
Ульяновск (8422)24-23-59  
Уфа (347)229-48-12  
Хабаровск (4212)92-98-04  
Челябинск (351)202-03-61  
Череповец (8202)49-02-64  
Ярославль (4852)69-52-93

Единый адрес для всех регионов: [bya@nt-rt.ru](mailto:bya@nt-rt.ru) | | [www.bray.nt-rt.ru](http://www.bray.nt-rt.ru)